

ZWCAD+ Quick Reference

1. ZWCAD+ product line

1.1. Versions of ZWCAD+

ZWCAD+ has three commercial versions and two dedicated versions for academic users and developers. As shown below

For commercial users		
ZWCAD+ Standard	ZWCAD+ Professional	ZWCAD Mechanical
Fundamental	Fundamental	Fundamental
LISP	3D Module	3D Module
	API	API
Fundamental 2D drafting features and full LISP	Fundamental 2D drafting features, 3D module and a full set of APIs including LISP, VBA, ZRX and SDS	Mechanical Module Identical to ZWCAD+ PRO and enhanced by a full set of value-added tools and libraries for mechanical industry
ZWCAD+ Standard	ZWCAD+ Professional	ZWCAD Mechanical

- ZWCAD+ Standard has the fundamental 2D drafting features and full LISP support.
- ZWCAD+ Professional has the fundamental 2D drafting features, 3D viewing and editing module and a full set of APIs including LISP, VBA, ZRX and SDS.
- ZWCAD Mechanical is based on ZWCAD+ Professional and enhanced by a full set of value-added tools and libraries for mechanical industry.

1.2. System Requirement

Recommended System Requirements

- ✓ Microsoft Windows XP SP2 or higher/Vista/7/Server2003/Server2008
- ✓ All CPUs on supported hardware
- ✓ 1G RAM
- ✓ 1.5GB free disk space
- ✓ 1024 x 768VGA display with True Color
- ✓ 128MB graphics card
- ✓ Microsoft Internet Explorer 7.0 or later
- ✓ Install from download or CD

1.3.Comparison with ZWCAD /AutoCAD

ZWCAD+ VS ZWCAD VS AutoCAD							
	Features	ZWCAD+ 2012		ZWCAD 2012		AutoCAD 2012	
		Pro	Std	Pro	Std	Full	LT
General	Dual-core utilization	√*	√*	×	×	√	√
	DWG version 2.5 to 2012	√	√	√	√	√	√
	Ribbon	√*	√*	×	×	√	√
	Multiline	√	√	√	√	√	×
	Drawing tabs	√	√	√	√	×	×
	SmartMouse	√*	√*	×	×	×	×
Annotation	Associative dimensions	√*	√*	√	√	√	√
	Leader & Qleader	√	√	√	√	√	√
	Table (import&export, table style)	√	√	√	√	√	√
	Text and Mtext	√	√	√	√	√	√
	Field	√*	√*	√	√	√	√
Layer	Layer manager	√	√	√	√	√	√
	Layer translator	√	√	√	√	√	×
	Layer previous	√*	√*	×	×	√	√
Xref, Block and attribute	OLE	√	√	√	√	√	√
	Images	√	√	√	√	√	√
	Xref	√	√	√	√	√	√
	Multiple block inserting	√	√	√	√	√	×
	Attribute (manager, synchronize)	√*	√*	√	√	√	√
Advanced	Design center	√	√	√	√	√	√
	Tool Palette	√*	√*	√	√	√	√
	Cycle select	√*	√*	×	×	√	√
	File Comapre	√	√	√	√	×	×
	Parametric drawing	×	×	√	√	√	×
	Express tools	√	√	√	√	√	×
3D	3D modeling (Solid, surface, mesh)	√	×	√	×	√	×
	3D editing	√	×	√	×	√	×
	Visual styles(Hide & Shade)	√	√	√	√	√	×
Programming	Full LISP support with vl-, vlr-, vla- and vlax- support	√*	√*	√	√	√	×
	Visual Basic for Applications (VBA)	√*	×	√	×	√	×
	Script recorder	√*	√*	√	√	×	×
	Runtime Extension(ZRX/ARX)	√*	×	√	√	√	×
	Full Diesel expressions	√*	√*	×	×	√	√
Outputting	Publish	√	√	√	√	√	√
	Ploting	√	√	√	√	√	√
	Export	√	√	√	√	√	√

2. Interface of ZWCAD+

2.1. Locations of the tools

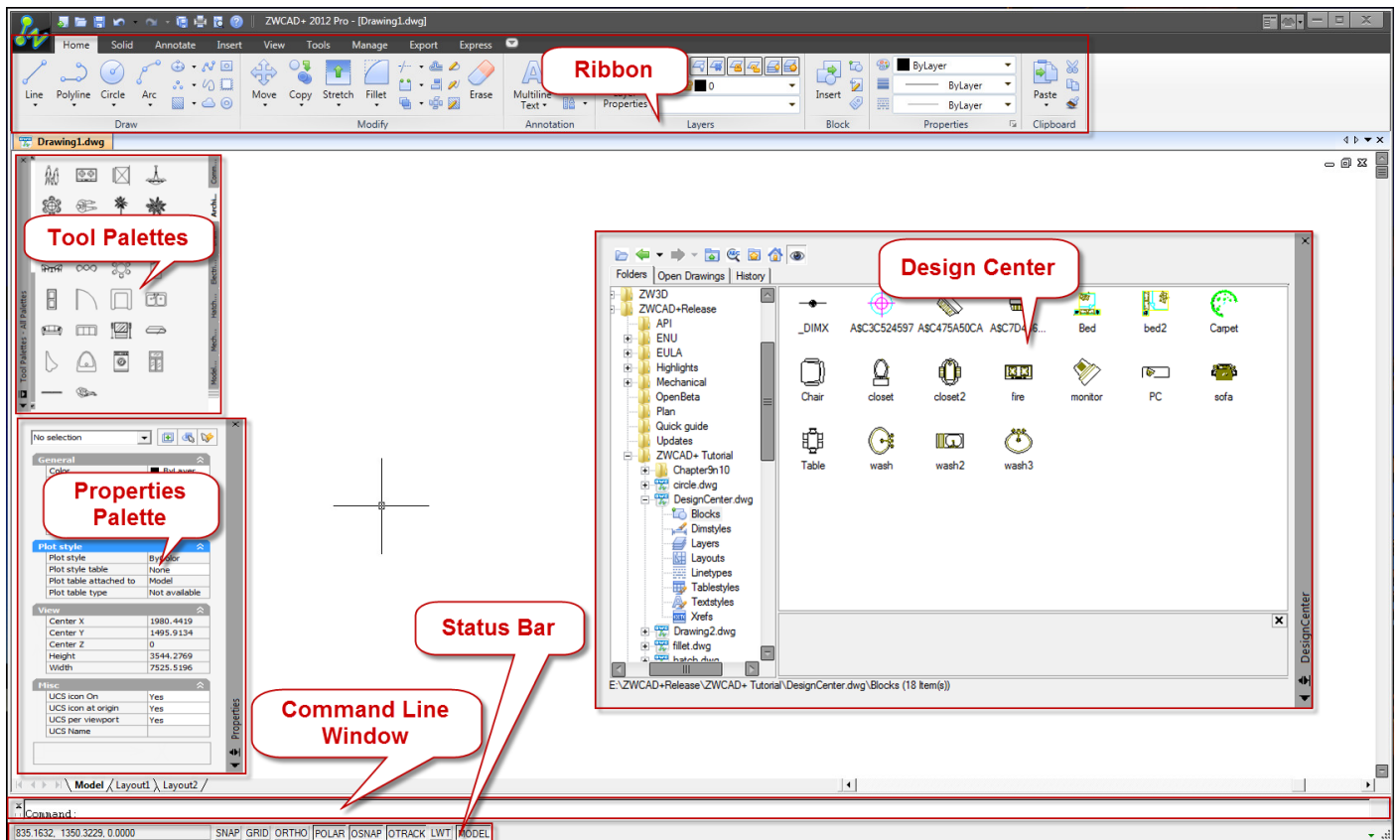

- **Ribbon** Maximize the area available for work using a compact interface that contains many of the same tools and controls available in toolbars and dialog boxes.
- **Tool Palettes** Organize, share, and place tools that are dragged from your drawing onto a tool palette or are provided from third-party developers.
- **Properties Palette** The Properties palette lists the current settings for properties of the selected object or set of objects. You can modify any property that can be changed by specifying a new value.
- **Design Center** With DesignCenter, you can organize access to drawings, blocks, hatches, and other drawing content. You can drag content from any source drawing to your current drawing. You can drag drawings, blocks, and hatches to a tool palette. Source drawings can be on your computer, on a network location, or on a website
- **Command Line Window** Execute a command by entering the full command name or command alias at the command prompt and pressing ENTER or SPACEBAR. When Dynamic Input is on and is set to display dynamic prompts, you can enter many commands in tooltips that are displayed near the cursor.
- **Status Bar** View the coordinate values of your cursor, and access several buttons for turning drawing tools on and off such as the snap mode, grid mode, tracking mode.

2.2. Mouse for ZWCAD+

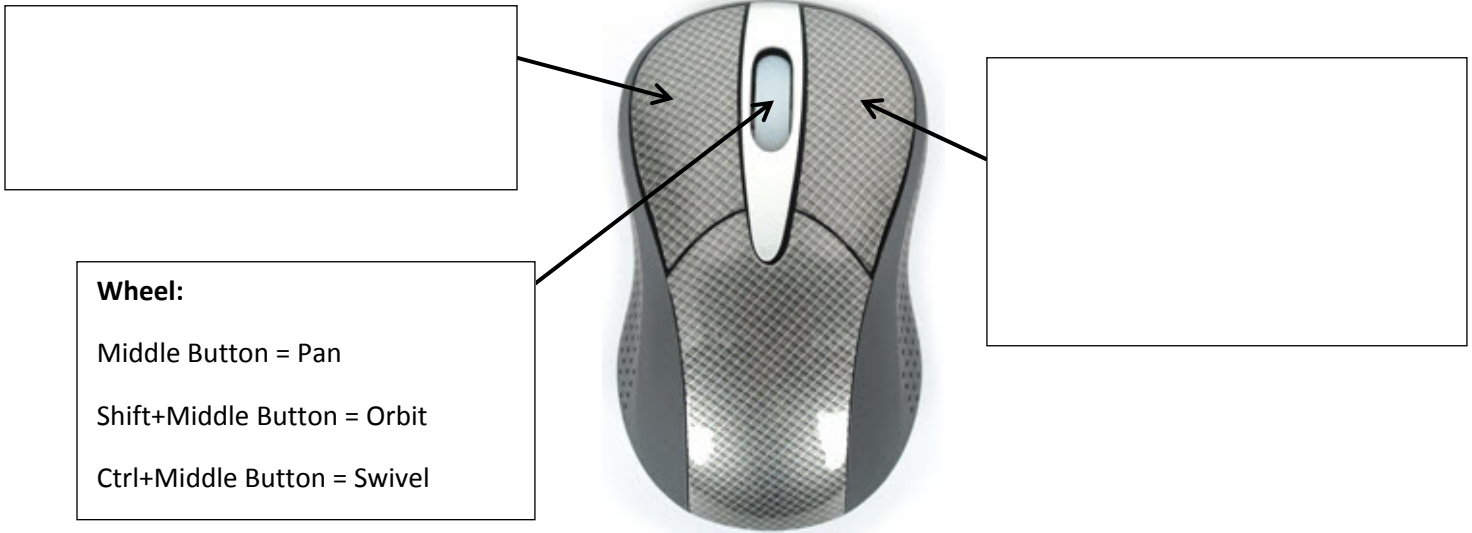

2.3. Find your shortcuts in ZWCAD+

2.3.1. Aliases

ZWCAD+ comes with a large number of aliases to help you easily to access the command through command line.

Frequently used aliases:

A,	*ARC	RE,	*REGEN
ATT,	*ATTDEF	REC,	*RECTANG
AR,	*ARRAY	T,	*MTEXT
B,	*BLOCK	VP,	*DDVPOINT
C,	*CIRCLE	W,	*WBLOCK
D,	*DIMSTYLE	Z,	*ZOOM
E,	*ERASE	...	

2.3.2. Hot keys

KEY	FUNCTION	KEY	FUNCTION
F1	Help	Ctrl+A	Select all
F2	Text Window	Ctrl+B	Snap
F3	Object Snap Toggle	Ctrl+C	Copy
F4	Tablet toggle	Ctrl+D	Coords
F5	Isoplane switching	Ctrl+E	Isoplane
F6	Coordinate display toggle	Ctrl+G	Grid
F7	Grid toggle	Ctrl+K	Hyperlink
F8	Ortho toggle	Ctrl+N	New

F9	Snap toggle	Ctrl+O	Open
F10	Polartoggle	Ctrl+P	Plot
F11	Object snap tracking toggle	Ctrl+S	Qsave
		Ctrl+T	Tablet
Ctrl+1	Properties palette display toggle	Ctrl+V	Paste
Ctrl+2	Design Center display toggle	Ctrl+X	Cut
Ctrl+3	Tool Palettes display toggle	Ctrl+Z	Undo

3. Precision Tools

3.1.Coordinate system

To locate points precisely you can enter coordinates as either Cartesian (Rectangular) or polar coordinates, with both Cartesian and polar coordinates, you can either enter absolute coordinates based on the origin, or relative coordinates based on the last point

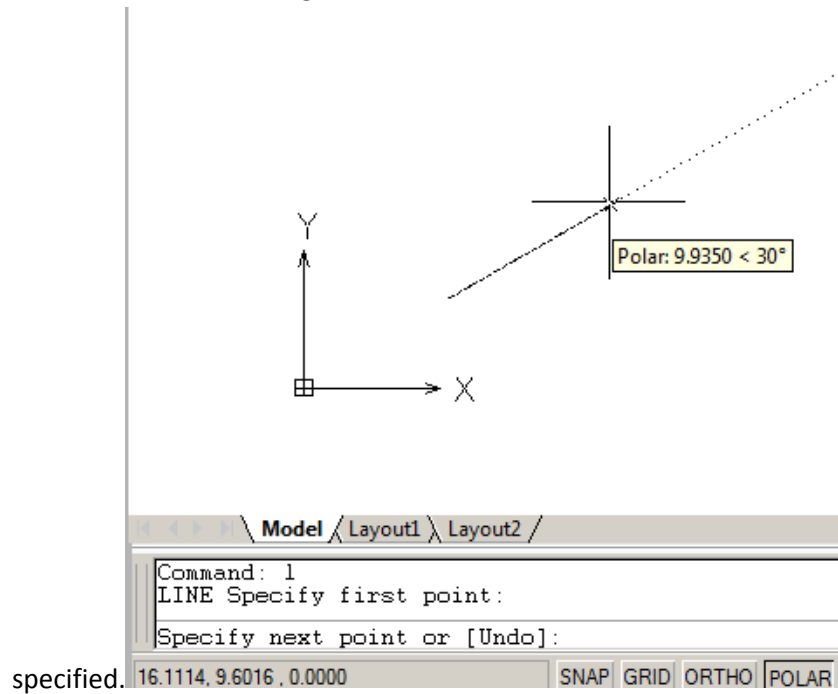

	Absolute	Relative
Cartesian	X,Y(,Z)	@X,Y(,Z)
Polar	Dist<angle	@Dist<angle

Example 1:

Command: rectang

1st point: 70,80

2nd point: @30,40

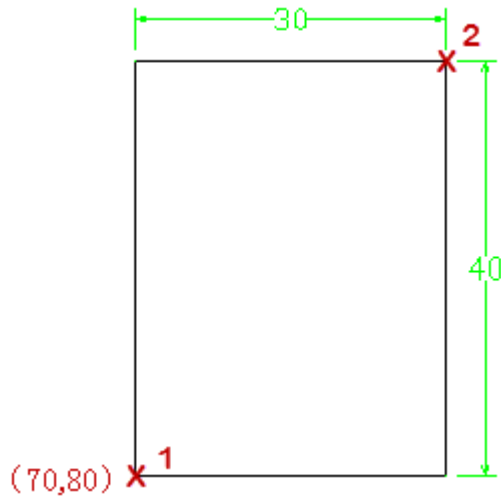

Example 2:

Command: LINE

1st point: 0,0

2nd point: 20<30

3rd point: 20<145

4th point: @20<145

5th point: @40<30

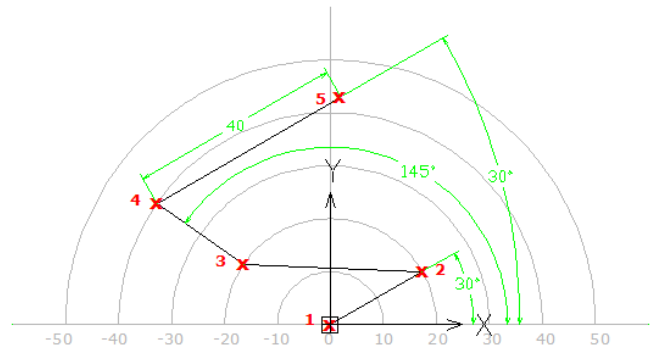

Tips & Tricks:

1. When polar tracking is on, you can enter a relative coordinate by moving the cursor to specify a direction and input the distance in the command line directly.
2. Please note that the UNITS command controls the unit format, choose the one you need.

3.2. Object Snap (Snap to the location on objects)

Instead of entering coordinate, you can specify points where the existing objects located on ,such as endpoints of lines and center points of circles in ZWCAD+

3.2.1. Access object snap

1. Right-click menu

Hold down Shift and right-click mouse button, the OSNP menu will be shown at your cursor location.

2. Turn on running OSNP

Turn on running OSNP on the status bar, then you can use one or more object snap mode repeatedly at work.

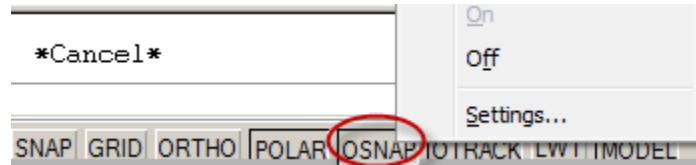

Go to OSNAP Settings, select the object snap you want to use:

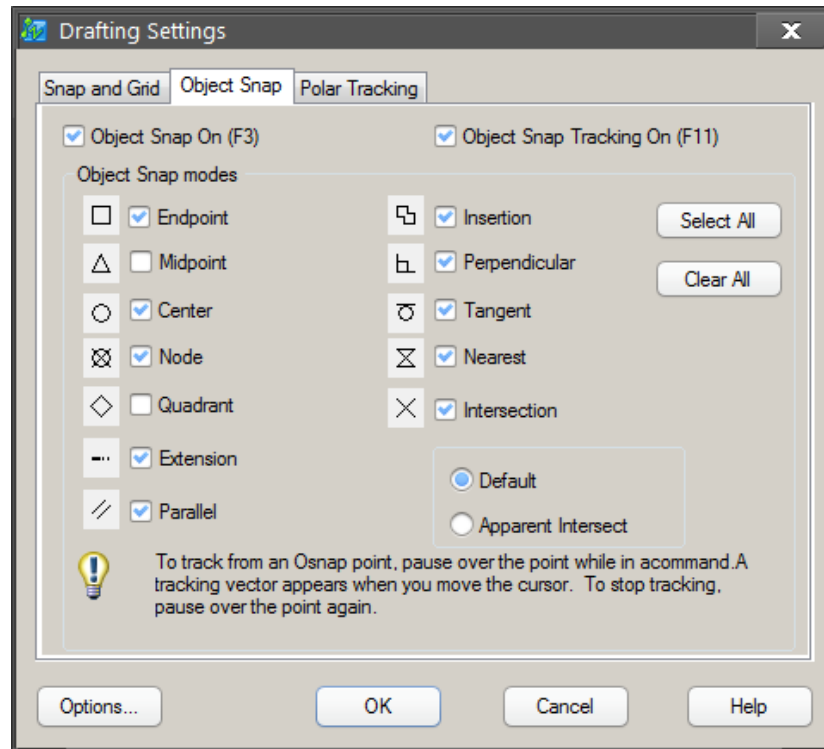

3.2.2. Set OSNAP Visualappearance

To help you see and use object snap more efficiently, ZWCAD+ OSNAP displays a marker and tooltip when the cursor is over an object snap location.

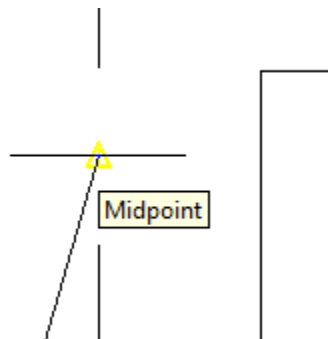

And you can change the setting as you like:

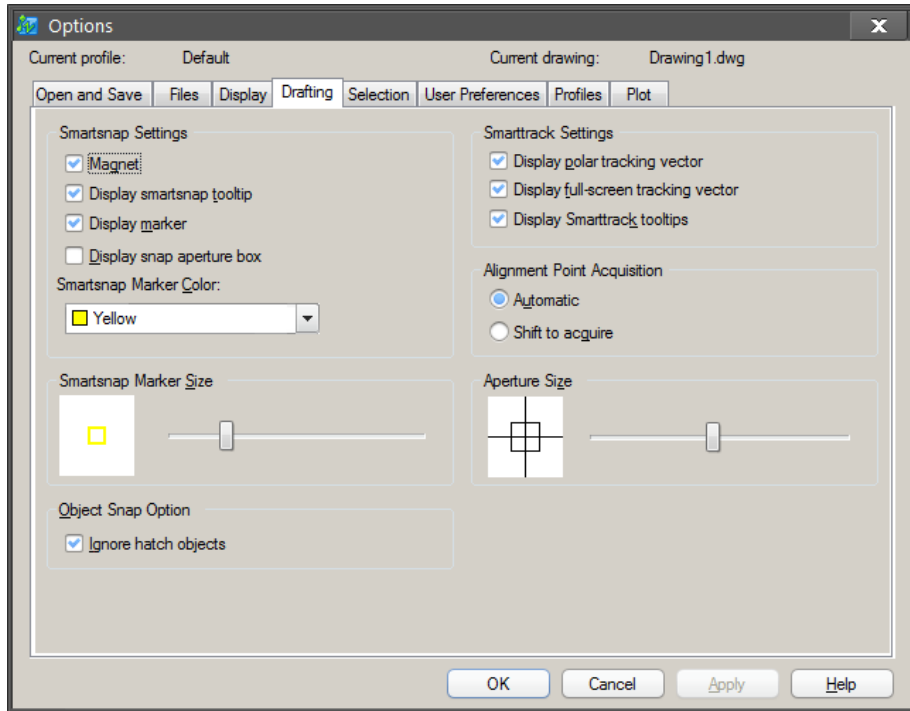

3.3.Polar Tracking: restrict the movement of your cursor

To make your work more fluently and efficiently, sometimes you need to lock your cursor movement to some specific angle, turn on ZWCAD+ polar tracking and set the angle you want.

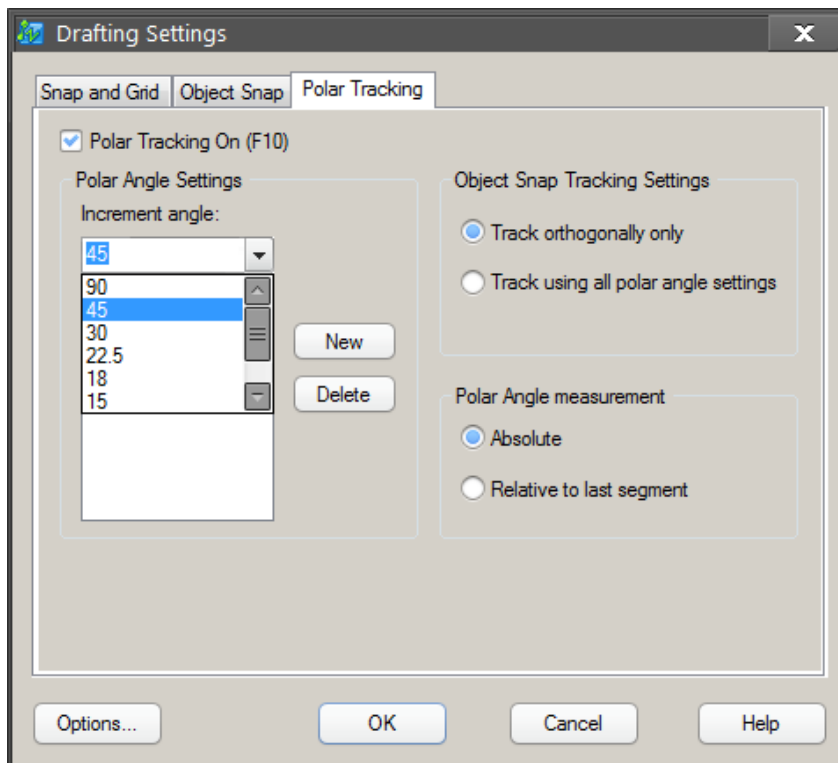

Especially if you want to move vertically or horizontally, there is ORTHO on the status bar.

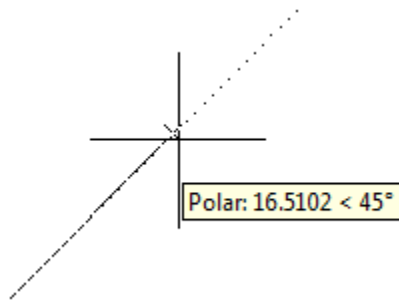

4. Create Objects

ZWCAD+ provides a series of tools as following to help you create objects conveniently. The key rule is to specify points and enter some necessary values following the command prompts.

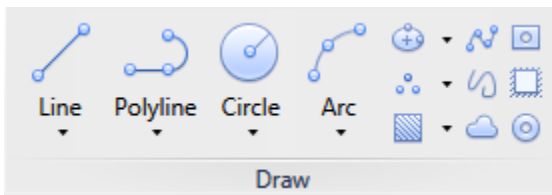

Example 1: DrawLines

1. Click Home tab → Draw panel → Line
2. The command prompts you to specify a point, here you can use your pointing device, or you can enter the coordinate values.
3. After you specify a point the command will prompt you to specify the next point, and it won't stop until you press ESC key

Command: `_line` Specify first point: 100,100

Specify next point or [Undo]:

Specify next point or [Undo]:

Specify next point or [Close/Undo]:

Specify next point or [Close/Undo]: 130,140

Specify next point or [Close/Undo]:

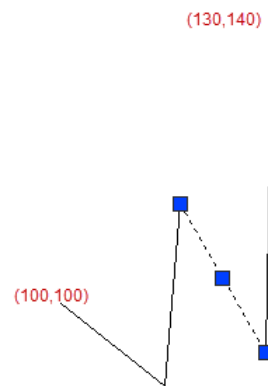

Note:

1. Here we use once the `LINE` command and get 4 line segments.
2. **Close** option is to join the first and last segments. **Undo** is to get back to previous segments.

3. **Enter key:** 1)Accept the values entered 2) call the previous command again
ESC key: cancel or discard the values

Example 2: Draw Circles

You can draw circles in several ways, combining center, radius, diameter, points on circumference.

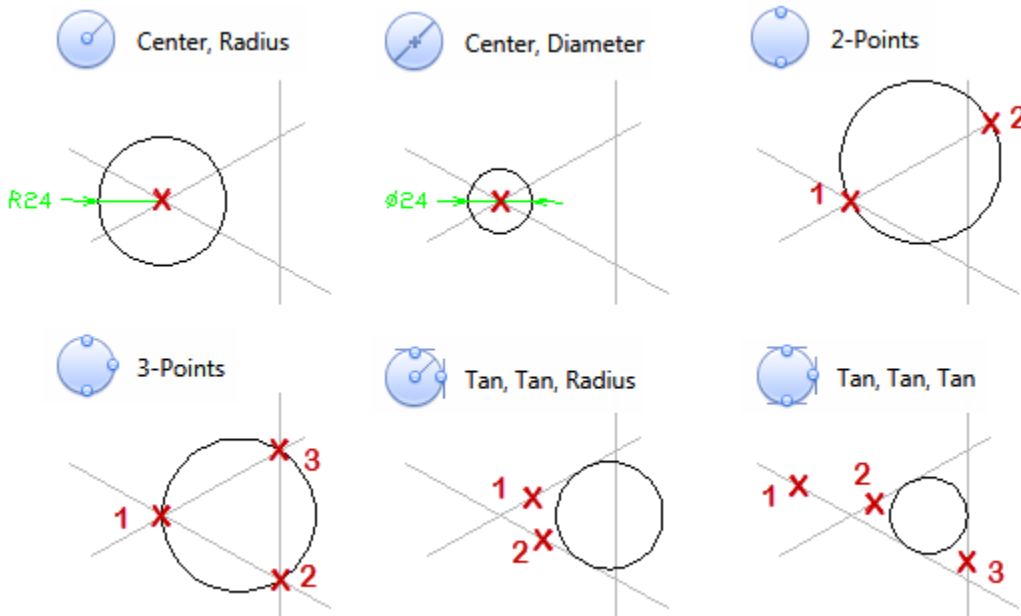
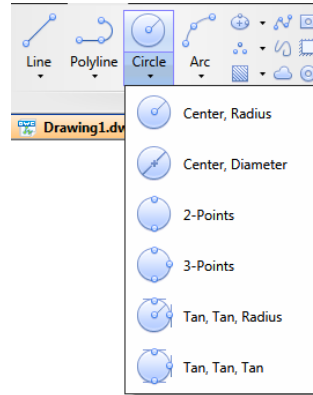

Example 3: Draw Polylines

A polyline is a connected sequence of straight line segments, arc segments, or a combination of the two, ZWCAD+ creates it as a single object.

Note:

1. You can create polyline with various widths in different segments, and you can create a tapering line segment by assigning different values for starting width and ending width.
2. If you want to switch to Arc mode, enter **a** (Arc) at the command prompt, if you want to back to Line mode, enter **l** (Line).

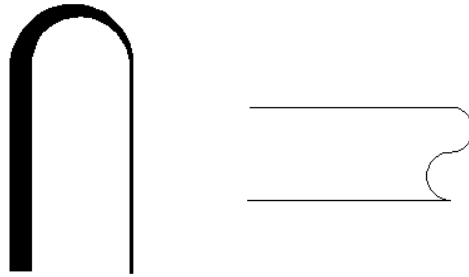

Relative command:

1. PEDIT All the line segments are treated as a whole, use PEDIT to edit a polyline
2. BOUNDARY Creates a boundary (set) from an enclosed area, the boundary could be a region or a polyline.

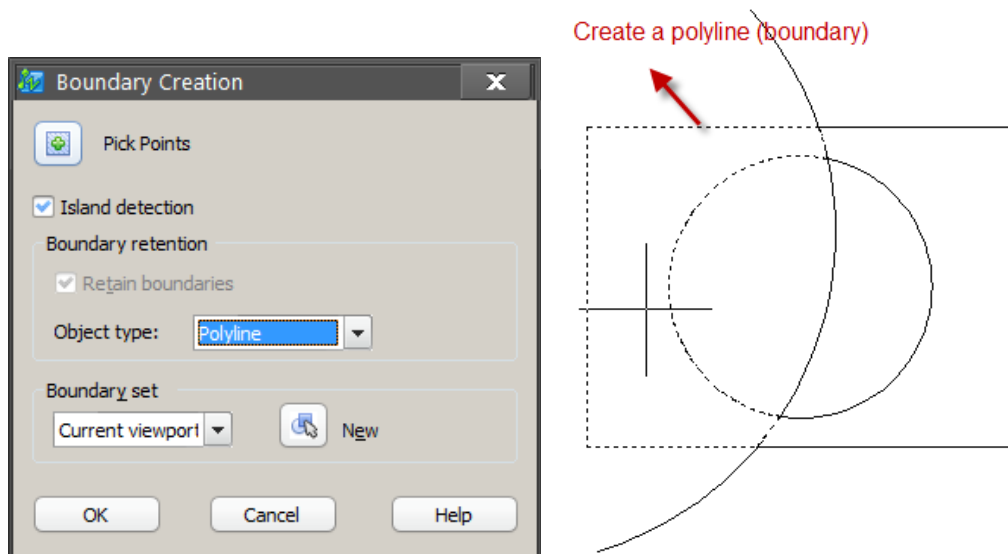

Use the similar skills as above three examples shown, you can create the other objects listed on the draw panel such as Ray/Xray/Polygon/Rectangle/Arc/Ellipse/spline ect.

5. Select and Modify Objects

Except for those basic geometries introduced in last chapter, you can also create more complex objects by editing the existing objects.

5.1. Methods to Modify Objects

- **Command Line** Enter a command and then select the objects to modify. Or you can select the objects first and then enter a command. Follow the command prompts you can finish all the procedures.
- **Shortcut Menu** Select and right-click an object to display a shortcut menu with relevant editing options

- **Properties Palette** In Properties Palette, you can specify a new value to modify any property that can be changed. Usually you double-click the object and the properties palette shows.
- **Grips** Select an object to display the grips, and click a grip to make it active, you can activate multiple grips by pressing SHIFT when click them. With those activated grips you can stretch the objects by default, or you can chose the other grip mode by pressing the Enter or Spacebar to cycle through the grip modes: move, rotate, scale, and mirror.

5.2. Select objects you want to edit

There are many ways to select objects:

1) Use the Pickbox Cursor and select objects one by one

Sometimes it is difficult to select objects that overlap or are close together, in this situation hold down SHIFT and click SPACE to cycle through the objects until the one you want is highlighted, click ENTER to confirm your selection.

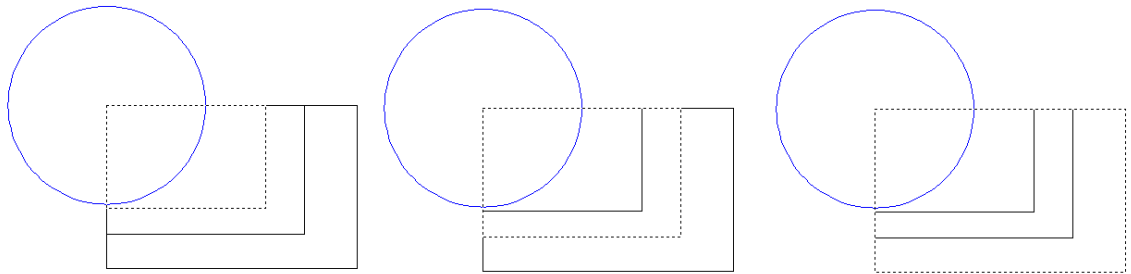

2) Specify a Selection Area and select Multiple Objects

- **Window Selection:** Drag your cursor from left to right to select only objects that are entirely enclosed by the rectangular area.

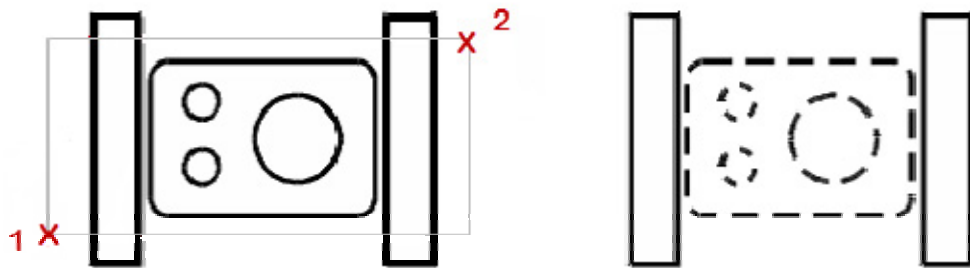

- **Crossing Selection:** Drag your cursor from right to left to select objects that the rectangular window encloses or crosses.

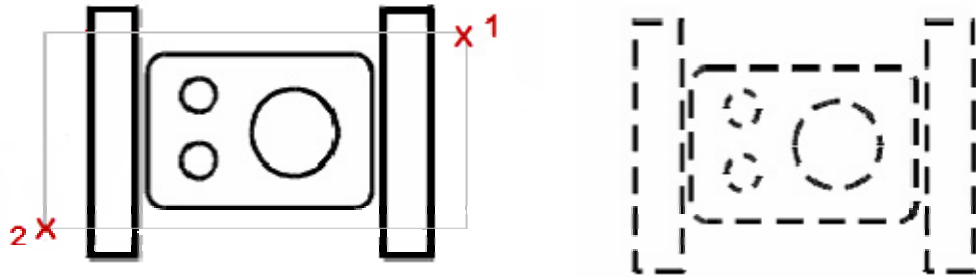

- **Selection Fence:** select the objects that the fence passes through



Tips & Tricks

- ✓ Objects on the locked layers can not be selected unless you unlock those layer
- ✓ You can use QSELECT or FILTER to select objects by property and by object type.
- ✓ You can specify a set of objects as a group, and you can easily select those objects and edit after because ZWCAD+ recognize it as a unit.

5.3. Erase objects

There are many ways to delete objects from your drawing and clean up the display:

- **ERASE** command to delete the objects selected
- Press **DELETE** key to delete the objects selected
- **PURGE** command can remove the unused named and unnamed objects such as block definition, dimension style, layers, line types and text styles. Purge can reduce the file size, your work will become easier and faster.

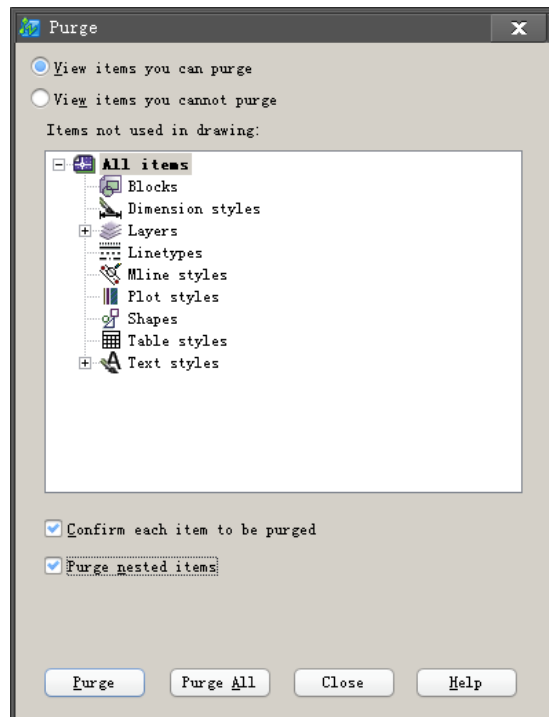

5.4. Move or Rotate Objects

You can move objects to a different location, or change the orientation of objects by rotating them by an angle.



5.4.1. Move Objects

To determine the distance and direction of the movements, you can specify a base point and destination point. In this example,

- 1) select the window
- 2) specify the base point for the move
- 3) specify the destination point and the window moved

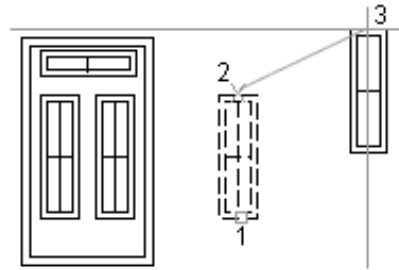

5.4.2. Rotate Objects

You can rotate objects around a specified base point. To determine the angle of rotation, you can enter the angle value, or using the cursor, or specify a reference angle to an absolute angle.

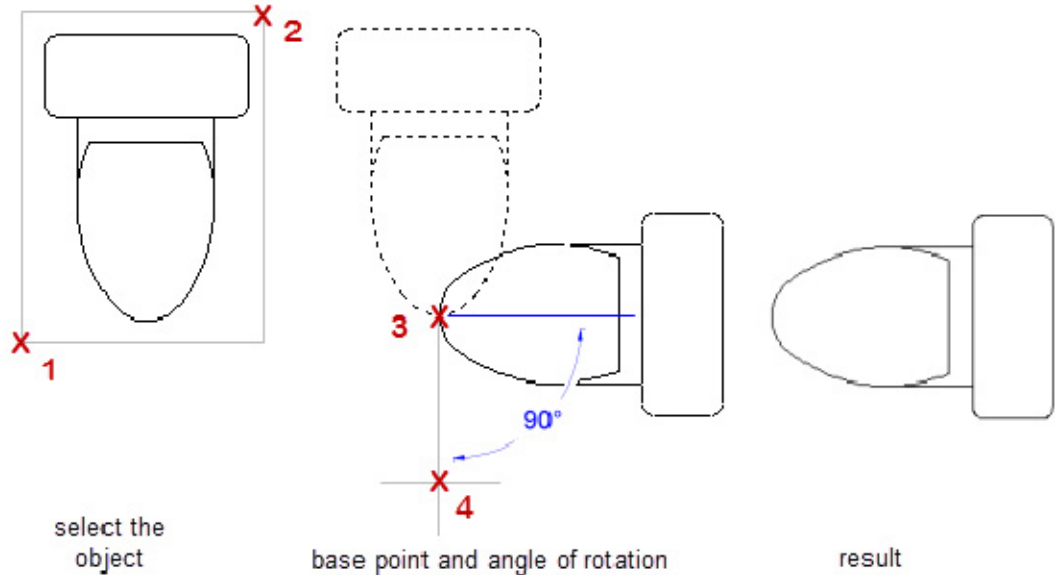

5.4.3. Align Objects

You can align an object with another by specify two pairs of points using ALIGN command.

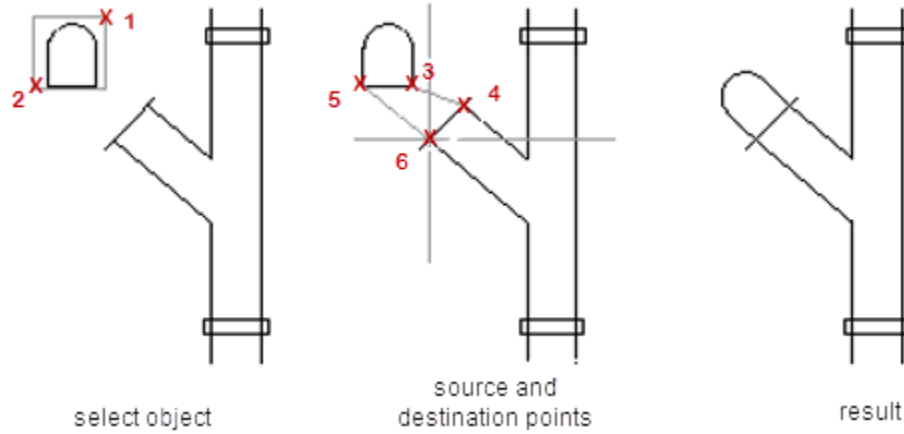

5.5. Create identical or similar Objects

There are many ways you can create duplicates of objects in your drawing that either identical or similar to existing objects, and you can locate them in some specific way.

5.5.1. Copy

You can create a single copy or multiple copies at specified distance and direction.

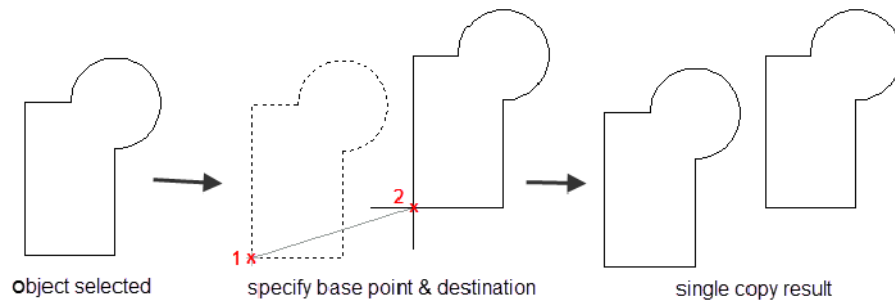

If you want to create multiple copies, you just need to specify multiple destination points.

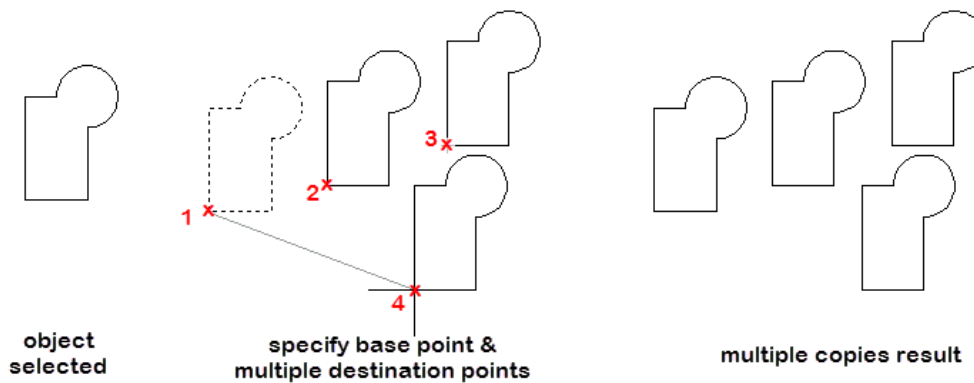

Tips & Tricks

- ✓ Copy is a multiple command which will repeat copying the last entity until canceled by Esc. Multiple command you would frequently use such as LINE, OFFSET and so on.
- ✓ If you want to repeat a command that does not repeat by default, you can press Enter or BlankSpace, or you can use MULTIPLE command to set it repeat by default.

5.5.2. Array

You can create multiple copies of objects that array in rectangular or polar pattern.

In rectangular array, you need to specify the no. of rows and columns, and the row offset and column offset, you can specify by entering the value or by referring points picked on the screen.

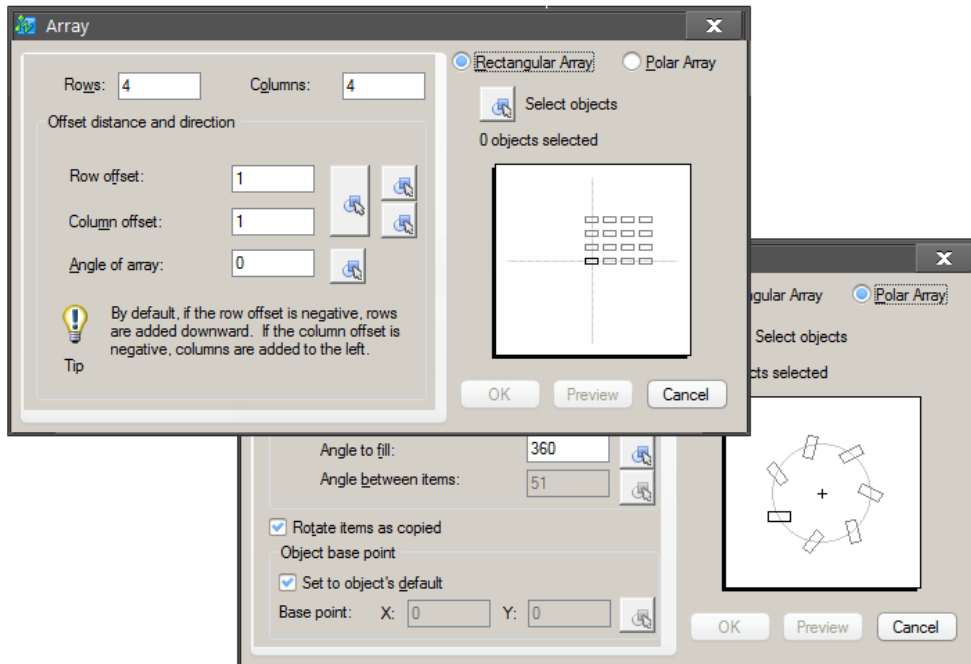

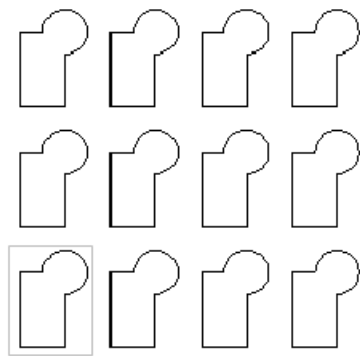

rectangular array

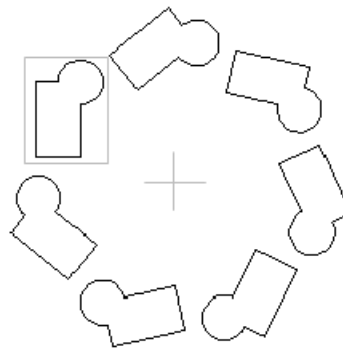

polar array

5.5.3. Offset

Offset an object can create new objects whose shape is parallel to the original object. OFFSET could be apply on objects such as arcs, circles, ellipses, elliptical arcs, lines, 2D polylines, rays, and infinite lines.

You can offset an object by specifying a distance, or you can offset an object through a point.

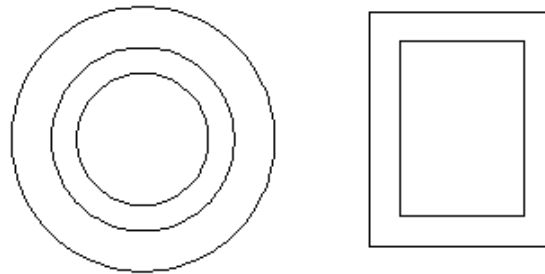

5.5.4. Mirror

The mirror image is symmetrical with the original one. So if you want to create a symmetrical objects, you only need to draw a half one, then create a full one using MIRROR command.

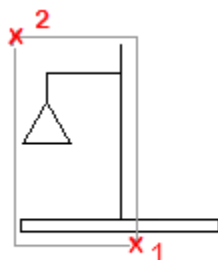

Select objects

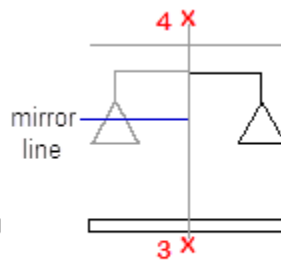

specify the mirror line

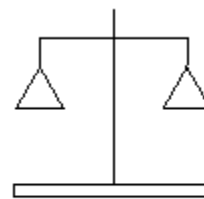

**result
(retain the original)**

To mirror an object you need to specify an axis, you could specify this temporary mirror line by entering two points. And you can choose whether to erase or retain the original objects.

5.6.Change the size and shape of objects

There are many ways for adjusting the size or shape of existing objects relative to other objects, both symmetrically and asymmetrically.

5.6.1. Trim

You can trim objects so that they end precisely at boundary edges by other objects. When trimming objects, you first select the cutting edges and then specify the objects to trim, selecting them either one at a time or using the fence selection method.

You can trim arcs, circles, lines, unclosed polylines, and rays. In which, arcs, circles, lines, polylines, rays, infinite lines, and viewports on a Layout tab can act as cutting edges..

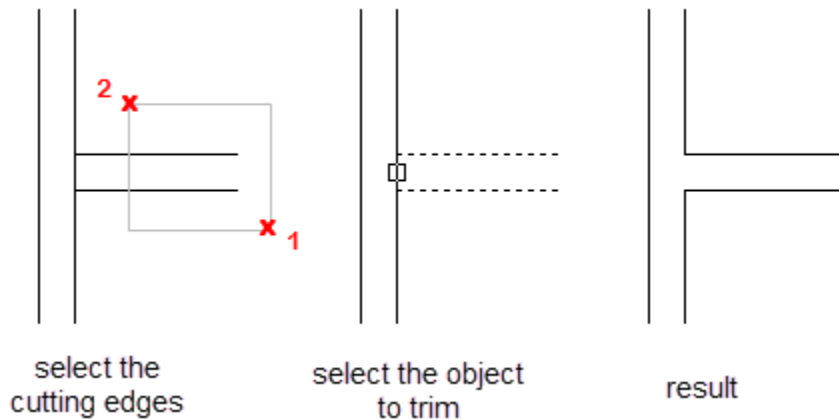

If you do not specify a boundary and press Enter at the Select Objects prompt, all displayed objects become potential boundaries. And an object can be one of the cutting edges and one of the objects being trimmed.

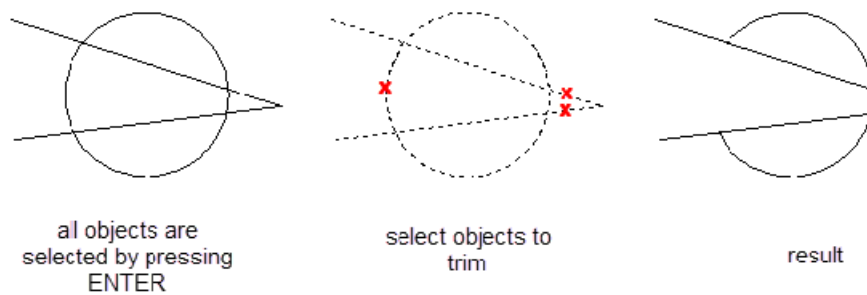

5.6.2. Extend

You can extend objects so they end precisely at boundary edges defined by the other objects. Extending operates the same way as trimming, first select objects as boundary then select objects to extend.

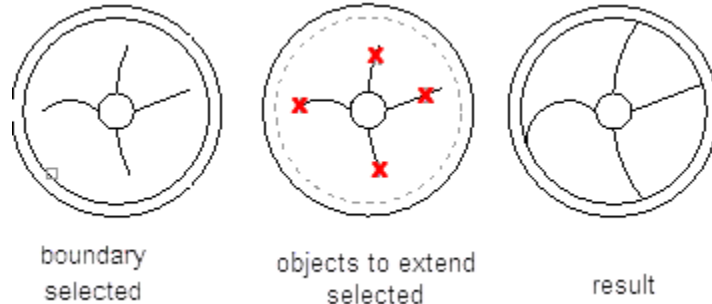

5.6.3. Stretch

You can change the size of objects by stretching them. When stretching objects, you have to specify a base point and displacement point. You should use crossing selection to select the desired objects. Objects that cross the window or polygon boundary are stretched. Those completely within the crossing window or crossing polygon are simply moved. With using grip edition, you can also stretch objects.

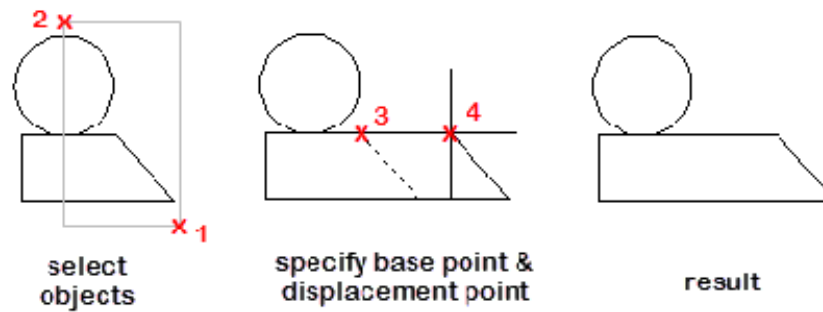

5.6.4. Scale

With SCALE you can enlarge or shrink the existing objects. There are two ways to scale objects:

- Using a scale Factor

You can specify a base point and a scale factor, if the factor is greater than 1 it enlarges the object, if the factor is between 0 and 1 it shrinks the object.

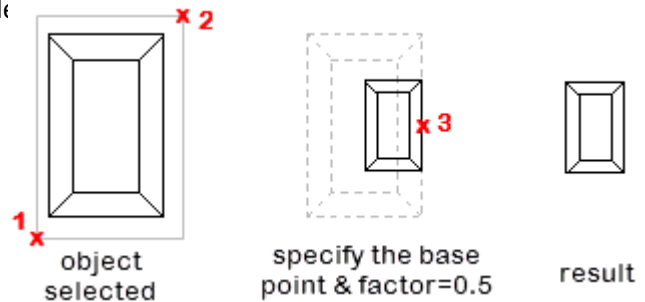

- **Using a reference distance**

You can specify the current distance and then the new desired size, the whole object will enlarge or shrink uniformly refer to the new desired size.

5.7. Fillet, Chamfer, Break, or Join the Objects

You can connect two objects with rounded or flattened corners. And you can create or close gaps in objects.

5.7.1. Fillet

A fillet connects two objects with an arc that is tangent to the objects and has a specific radius. To fillet the objects, you need to specify the location and the radius. You can fillet

Arcs/Circles/Ellipse/Lines/Polylines/Splines/Xlines.

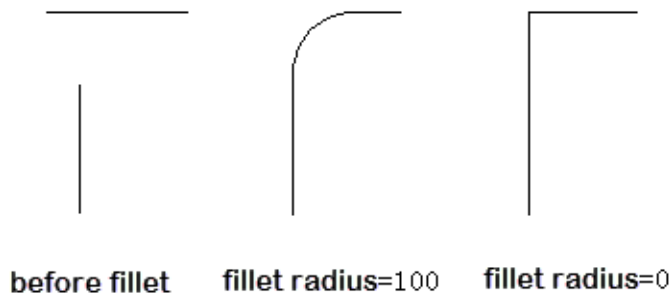
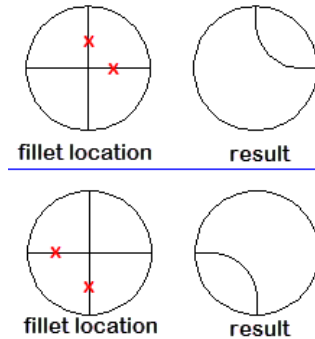

5.7.2. Chamfer

A Chamfer connects two objects with a beveled corner. To chamfer the objects, you need to specify the chamfer distances.

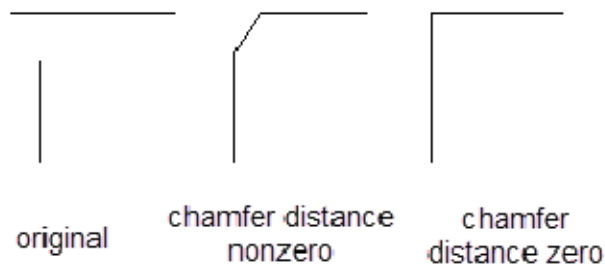

5.7.3. Break

You can create a gap in an object, resulting two objects with a gap between them. To break an object you need to specify two break points. By default, the point at which you select the object is the break point. To select a different pair of break points, enter **f** (First) and specify the first break point.

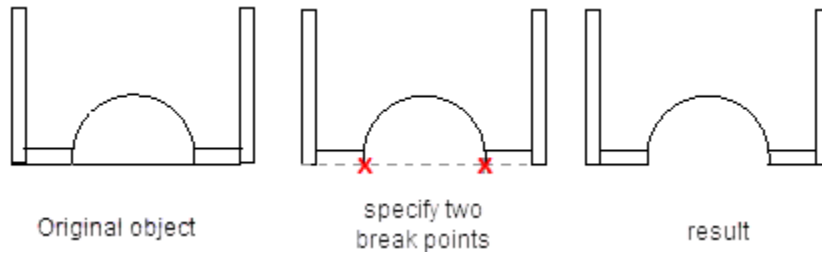

6. Work with Layers

Layers in ZWCAD are like the transparent overlays you use in manual drafting. You use layers to organize different types of drawing information. By creating layers, you can associate similar types of objects by assigning them to the same layer. For example, you can put construction lines, text, dimensions, and title blocks on separate layers

- **On /Off** Objects on turned-off layers are invisible, and they do not print.
- **Freeze/Thaw** Objects on frozen layers do not display, do not print, and do not regenerate which speeds up the operations.
- **Lock/Unlock** Objects on locked layers can not be modified until you unlock the layers.
- **Isolate/Unisolate** Isolate hides or locks all layers except those of selected objects.

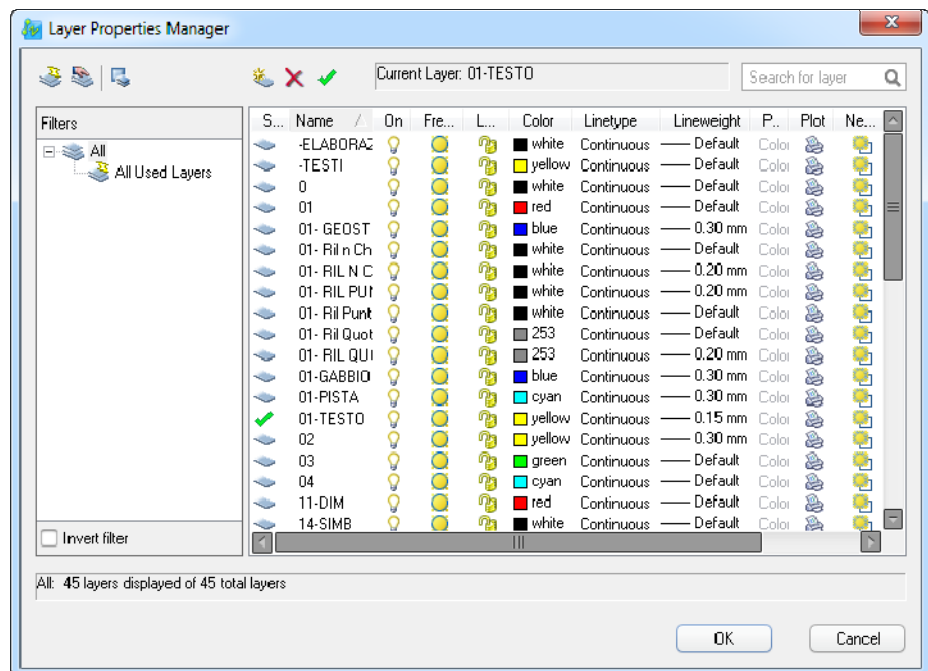
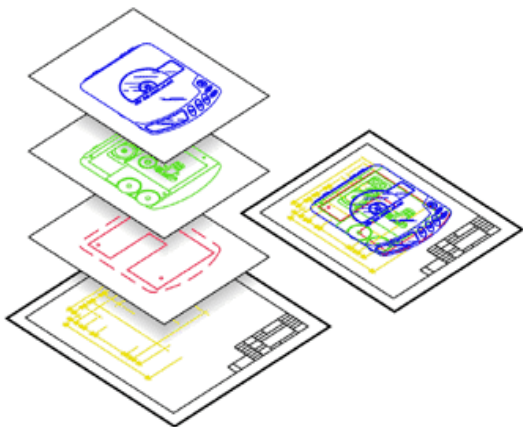

With layer Properties Manager, you can create new layer or edit the properties of selected layer. And you can save layer settings as a named layer states. You can then restore, edit, import, or export the states.

7. View (Zoom, Pan, UCS, view)

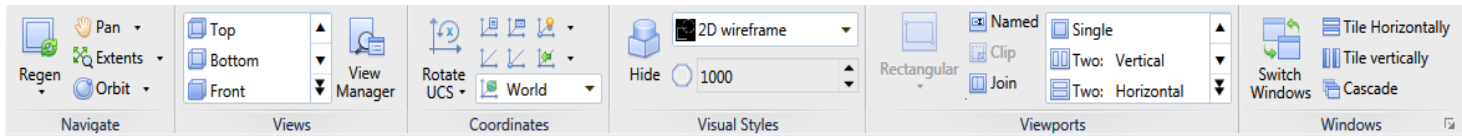

7.1.Zoom/pan

Working with CAD you usually need to magnify the details in your drawing for a closer view or shift the view to a different part of the drawing. Both of them only change the view of current drawing, not the real position or size of objects.

ZOOM and PAN are most frequently used command. There are many options for you when pan to reposition the view in the drawing and zoom to change the magnification.

- **Pan**

When you hold your middle mouse button and move it, it triggers the real-time panning, which enables you to view different part of the drawing.

You can also type the –PAN command to trigger pan by point function, in which you can specify the original point as the first one, and specify a new position for it to pan the whole drawing towards a certain direction and distance.

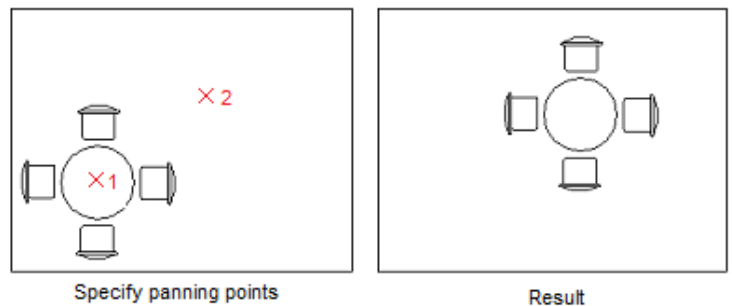

- **ZOOM**

Real-time zoom in and out by scrolling the middle mouse button in drawing area can change the magnification of the view.

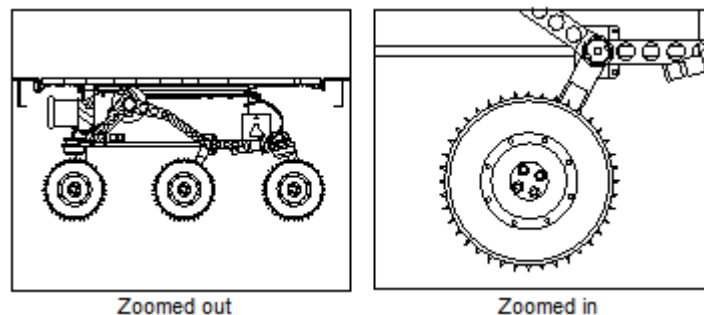

By using Zoom>Window, you can quickly zoom on a rectangular area of your drawing by specifying two diagonal corners of the area you are interested in.

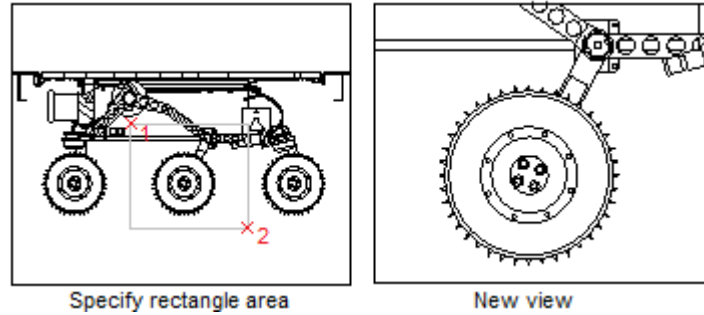

Zoom>Extent can be applied by double-clicking the middle mouse button, by which you can have the whole view of all the objects in your drawing. Besides, Zoom>All can also view all the objects, but if all the objects are inside drawing limit, Zoom>All will show all area the drawing limit.

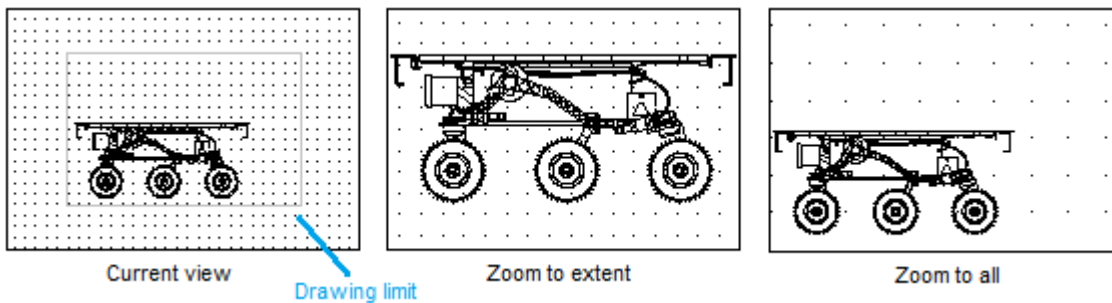

ZOOM>Objects displays a view with the largest possible magnification that includes all of the objects you selected. ZOOM>Previous helps you quickly go back to your last view.

7.2. Save and restore views

You can save views by name and restore them for plotting or when you need to refer to specific details. A named view is comprised of specific magnification, location and orientation.

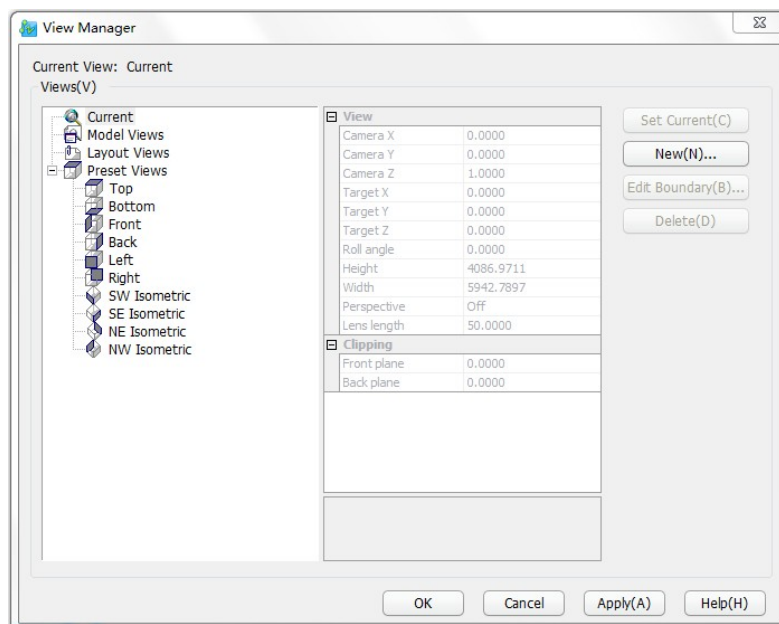

ZWCAD+ provides a view manager in VIEW command, in which you can save your current view, or restore a named view.

7.2.1. Save a View

When you name and save a view, the following settings are saved:

- Magnification, center point, and view direction
- The location of the view: the Model tab or a specific layout tab
- Layer visibility in the drawing at the time the view is saved
- User coordinate system
- 3D perspective and clipping

After saving a named view, you can find it in Ribbon: View tab > Views panel, then scroll the list box to the end.

7.2.2. Restore a Named View

Named views can be used to do the following:

- Restore views that you use frequently on the model space viewport or layout viewport.
- Specify the area to plot
- Determined which model space view is displayed when opening the drawing.

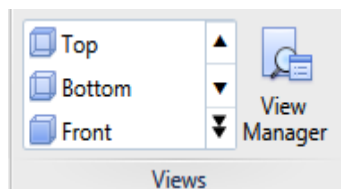

Preset Views

There are several preset views in ZWCAD+ that can be applied directly by clicking on list of views on Ribbon. It also includes the named views that created by user in this drawing.

Tips & Tricks

You can specify a layout view when you open the drawing only if you save the drawing from that specified layout tab.

7.3.UCS

User Coordinate System (UCS) is used for precise positioning of every point in the drawing area. It consists of value of different axis, X, Y and Z, so every point can be identified as (X, Y, Z). In two-dimensional drawing, we only use X and Y axis, so it can be reduced to (X, Y).

In each drawing, you will see a UCS icon at the left-bottom corner of drawing area that defines the origin of the drawing, which is (0, 0).

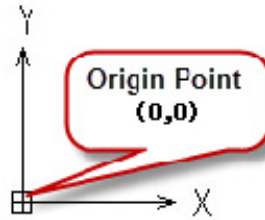

- **WCS**

WCS is short for World Coordinate System. It's the default coordinate system of every drawing.

- **UCS**

UCS here specifically refers to the coordinate system that customized by user. There are many ways to change the WCS to a certain UCS. You can either rotate the axis, or specify a new origin to it.

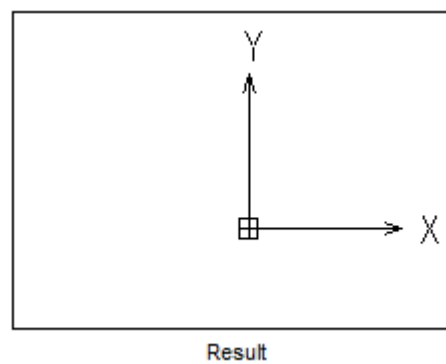
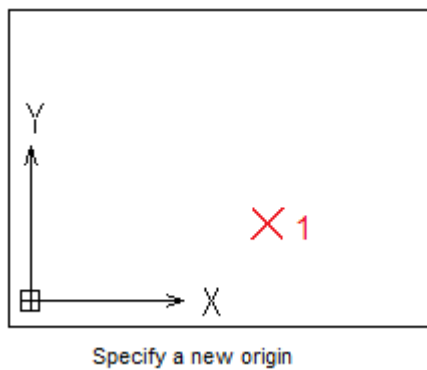
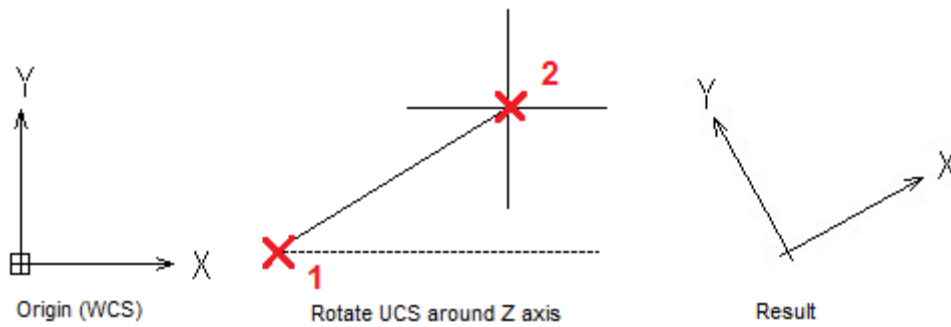

With UCS, we can easily find out the precise position of every point. Such as, we can see the detail coordinate value information of the start point and end point of a line in Properties panel.

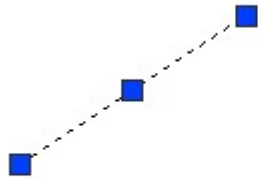

Geometry	
Start X	887.1994
Start Y	555.2652
Start Z	0
End X	1230.117
End Y	780.8634
End Z	0
Delta X	342.9175
Delta Y	225.5982
Delta Z	0
Length	410.4717
Angle	33

You can also know exactly where your cursor is at the moment, by the real-time coordinate information provided at the left bottom corner of the interface.

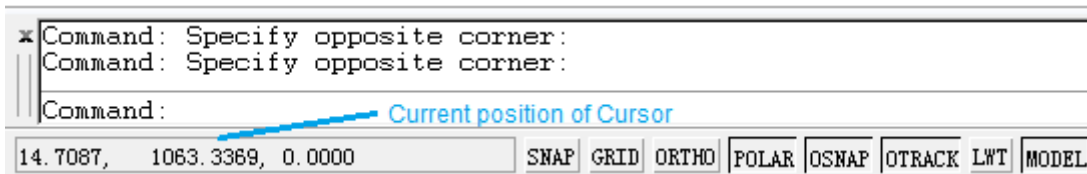

7.4.Viewports

In large or complex drawings, displaying different views reduces the time needed to zoom or pan in a single view. Also, errors you might miss in one view may be apparent in the others.

Viewport can be created both in model and layout space. As you make changes in one viewport, the others are updated simultaneously.

- Use Model Space Viewports

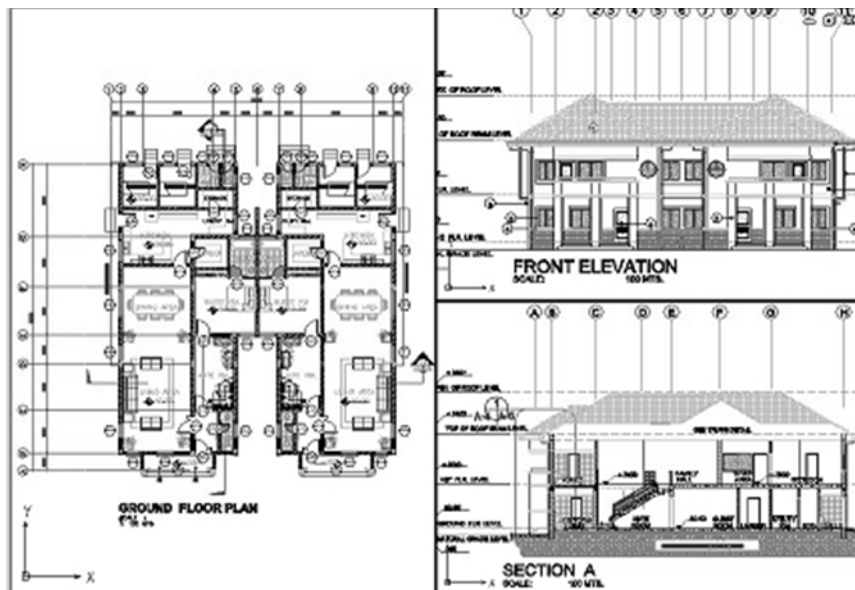

In model space, you can create viewports that completely fill the drawing area and do not overlap. In Ribbon environment, just turn to View tab > Viewports panel, there is a list box contains all preset viewport settings that can be applied directly.

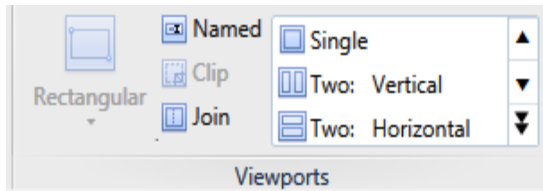

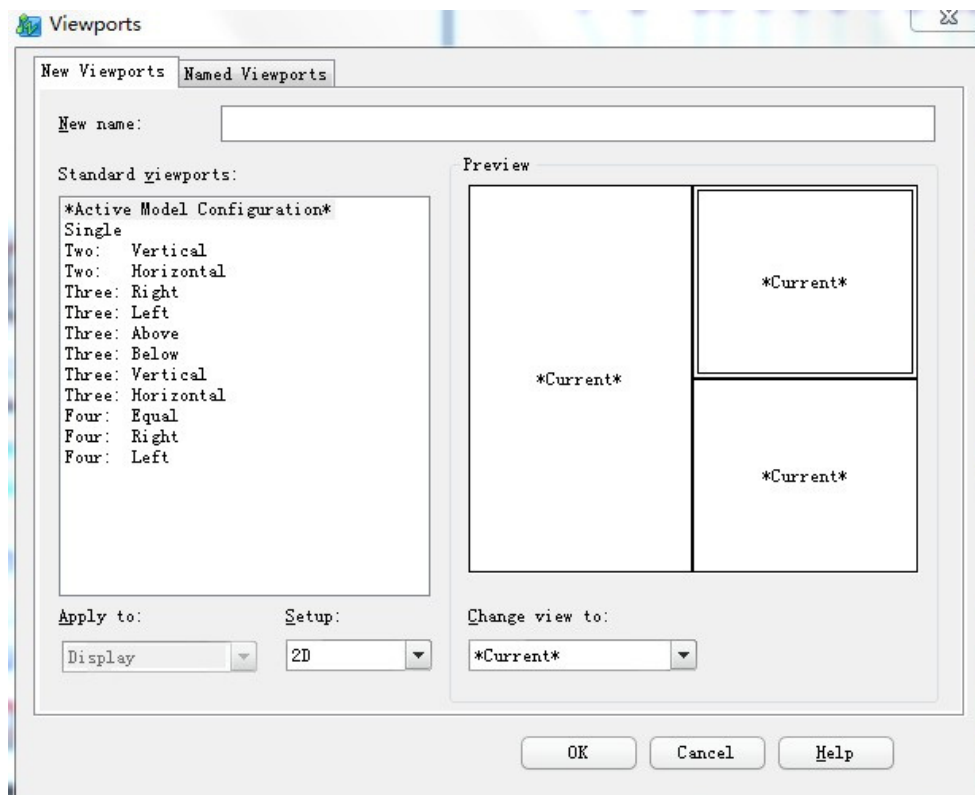

You can also enter Viewports Manager by VPORTS command. Here you can make more detailed settings to your viewports, such as create your own named viewports and specify different views to each viewport.

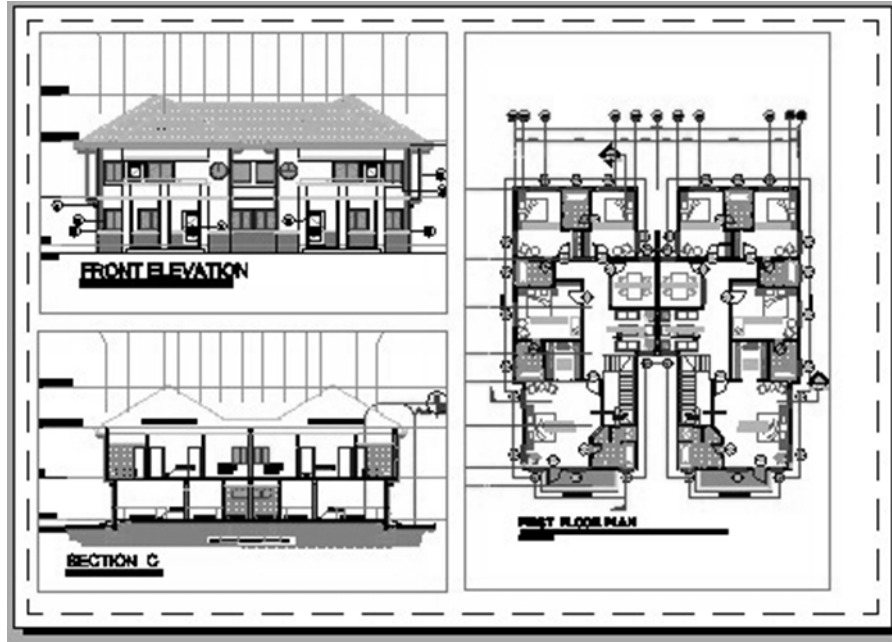

Use Layout Space Viewports

In layout space, you must create viewport to display drawings in model space. It seems like a “window” to see through model space. To create a viewport, you can click the Rectangle button on Ribbon: View tab > Viewport panel to create a rectangle viewport, or use the MVIEW command to do so.



 **Tips & Tricks**

You can use MVIEW command to quickly create several standard viewports at once by selecting 2, 3 or 4.

7.5. Visual Styles

Visual style is used in 3D modeling, in order to visualize solid models in different ways, especially in a more life-like appearance.

There are seven kind of visual styles provided in ZWCAD+, which are 2D wireframe, 3D wireframe, Hidden, Flat, Gouraud, Flat with edges, Gouraud with edges. Simply clicking on the gallery with visual styles in Ribbon: View tab > Visual Style panel can apply the chosen visual style in current drawing.

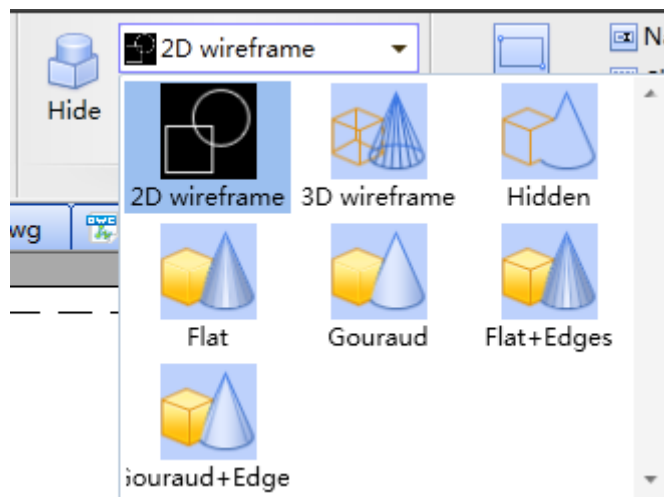

For more details of each Visual Style, please refer to *Chapter 12 – Work with 3D Models*.

8. Annotate Drawings

Annotations are notes or other types of explanatory symbols or objects that are commonly used to add information to your drawing. There are many types of objects playing the role of annotations such as dimensions, tolerances, text, tables, hatches, blocks and so on , in this chapter, we will introduce dimension, hatch, text and table.

8.1.Hatch and Fills

A hatch object is to highlight an area , or to identify a material by filling the enclosed area or the selected objects with a hatch pattern, solid fill or gradient fill.

To create a hatch object, use the HATCH command, and the Hatch Dialog Box will guide you to finish the whole procedures: select the hatch area, choose the hatch pattern, and set some necessary parameters.

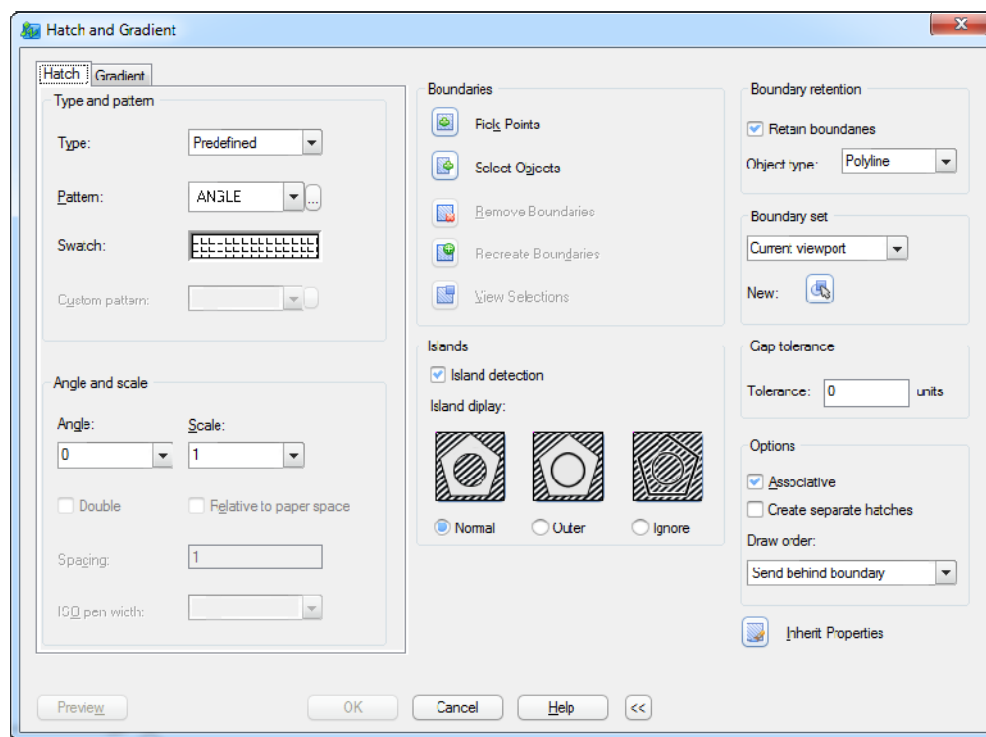

8.1.1. Specify the Hatch and Fill Areas

With ZWCAD+, you can specify the hatch and fills area by choosing an enclosed existing object, or pick a point, ZWCAD+ will calculate the area automatically. A hatch boundary can be any combination of objects, such as lines, arcs, circles, and polylines that forms an enclosed area.

- **Hatching in Islands**

Enclosed areas within hatch boundaries are called *islands*. You can specify methods of hatching objects in outermost boundary as normal, outer and ignore. Normal is the default hatch pattern.

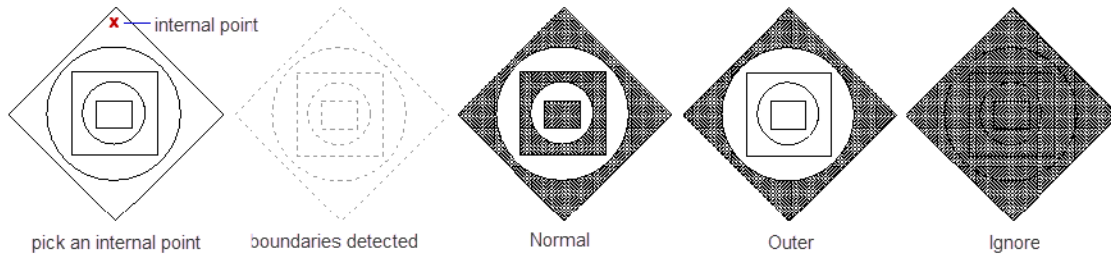

- **Select object for Hatching**

To raise the speed of hatching a small area of a complex drawing, you can define a set of objects in the drawing. HATCH does not analyze objects that are not included in the boundary set.

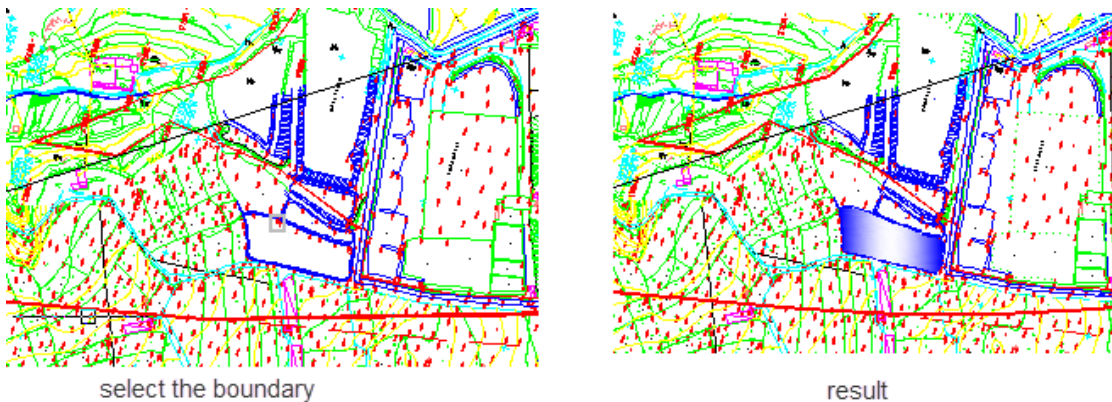

*Note: please be sure your hatch boundary is enclosed, or you can set the **Gap tolerance** if the boundary have small gap which you'd like to ignore.*

- **Associative Hatches**

Associative hatches are automatically updated when their boundary objects are modified. Minor changes in the boundary of an associative hatch do not require erasing and re-creating the

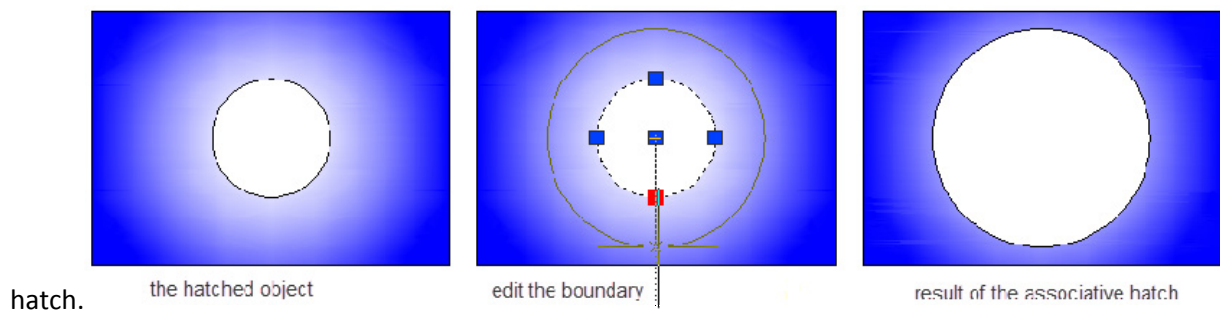

8.1.2. Specify the Hatch Patterns

There are two types of hatch patterns and two types of fills

- **Predefined hatch patterns**

There are about 80 patterns available. You can also use hatch pattern libraries supplied by other companies. Hatch patterns are defined in the *acad.pat* and *acadiso.pat* files.

- **Custom hatch patterns**

Define a custom hatch pattern definition in a .pat file. Setting proper **Scale** value and **Angle**, you can get different appearances with one hatch pattern as following.

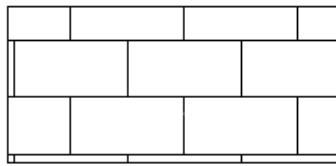

scale=1, angle=0

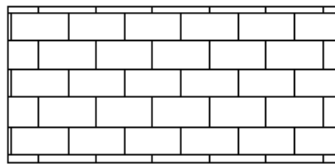

scale=0.5, angle=0

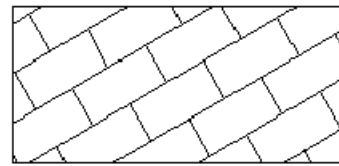

scale=0.75, angle=30

- **Solid fill**

Fill an area with a solid color by choosing the SOLID predefined hatch.

- **Gradient fill**

Fill an enclosed area with a color gradient. A gradient fill can be displayed as a *tint* (a color mixed with white), a *shade* (a color mixed with black), or a smooth transition between two colors.



8.2. Text

The text you add to your drawings conveys a variety of information. It may be a complex specification, title block information, a label, or even part of the drawing. You can create single-line text (TEXT) or multiline text (MTEXT), depending on your needs.

- **In-Place Text Editor**

Below is In-Place Text Editor, with which you can create and edit text .

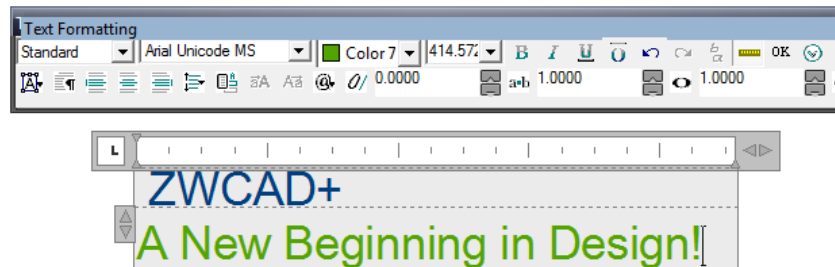

- **Text Styles**

You can customize the text style which determines the text font, size, angle, orientation, and other text characteristics, and save this information for reusing.

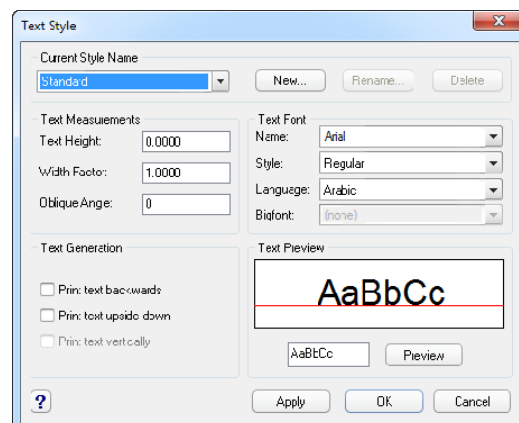

- **Field**

A field is updatable text that is set up to display data that may change during the life cycle of the drawing. When the field is updated, the latest value of the field is displayed. The fields are usually data such as Date, FileName, SheetNumberAndTitles which you expect to change during the life cycle of the drawing.

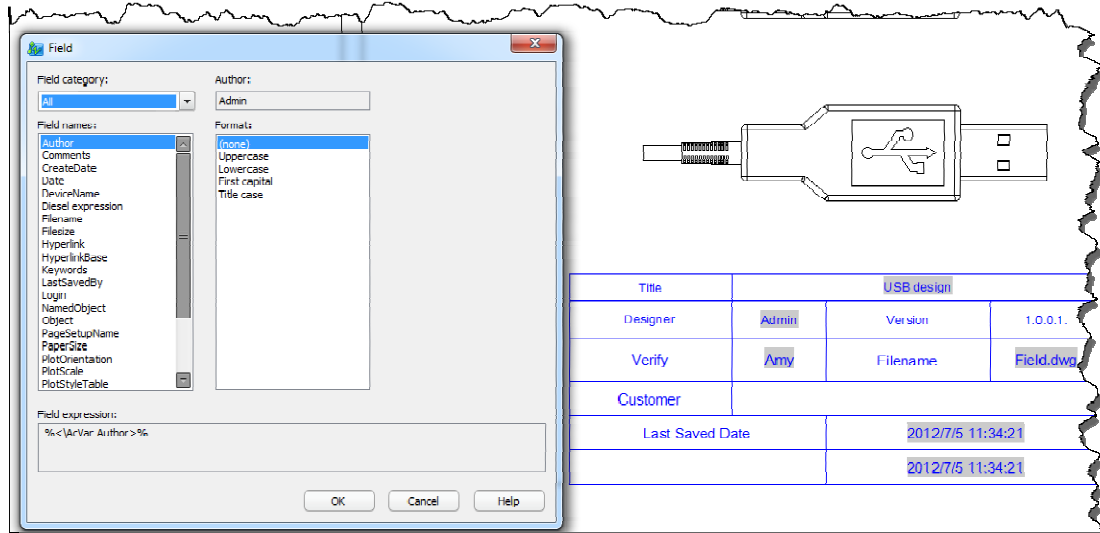

Tips & Tricks

When a field is updated, it displays the latest value. You can update fields individually or update all fields in one or more selected text objects.

Go to **Options** dialog box you can set the field automatically update rule. You can set fields to be updated automatically when the drawing is opened, saved, plotted, regenerated, or sent through ETRANSMIT.

- To make modification to a specific cell, click the cell and the content menu will show on the ribbon.

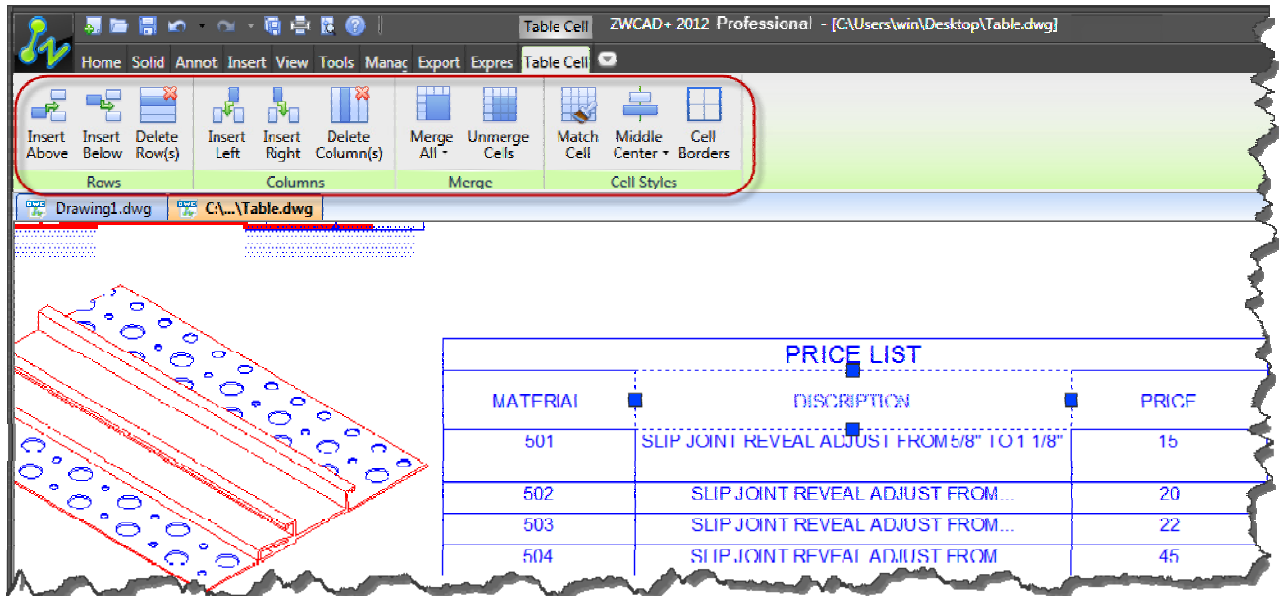

- To make a modification to the text in the cell, just double-click the text, you will get the text editor.

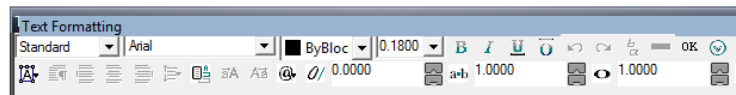

PRICE LIST		
MATERIAL	DISCRIPTION	PRICE
501	SLIP JOINT REVEAL ADJUST FROM 5/8" TO 1 1/8"	15
502	SLIP JOINT REVEAL ADJUST FROM...	20
503	SLIP JOINT REVEAL ADJUST FROM...	22
504	SLIP JOINT REVEAL ADJUST FROM...	45

8.4.Dimension

Dimension is the process of add measurement annotation to a drawing, you can create dimensions for a variety of object types in many orientations, and you can control their appearance by setting up dimension styles or by editing individual dimensions.

Dimensions indicate the measurement values of objects (e.g. length or width), distance or angles among objects, or the distance between feature point and the specified origin. You can create dimensions that can be horizontal, vertical, aligned, rotated, coordinate, baseline, or continued.

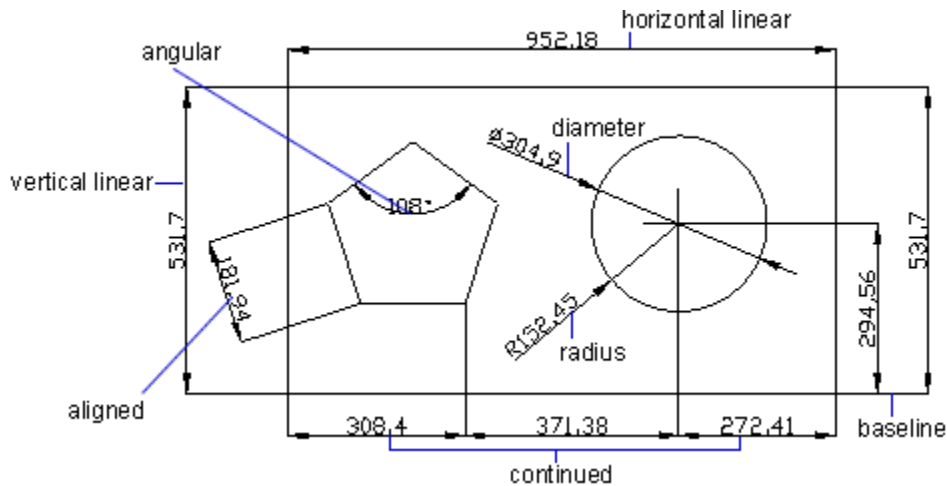

Create Dimension

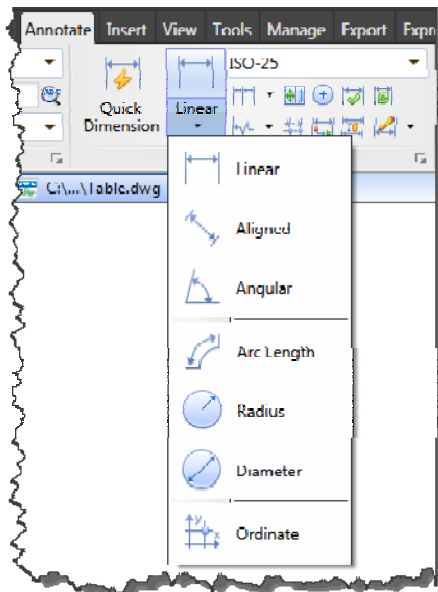

From **Annotate** Tab, you can find **Dimensions** Panel which provides dimensioning for a variety of object types in many orientations, such as Linear, Radial, Angular, Ordinate, Arc Length and so on.

Tips & Tricks

Associative dimensions can automatically adjust their locations, orientations, and measurement values when the geometric objects associated with them are modified. Dimensions in a layout may be associated to objects in model space. The DIMASSOC system variable is set to 2.

Dimension Style Manager

You can control the appearance of dimensions by changing the dimension styles, including arrowhead style, text location, and lateral tolerances and so on.

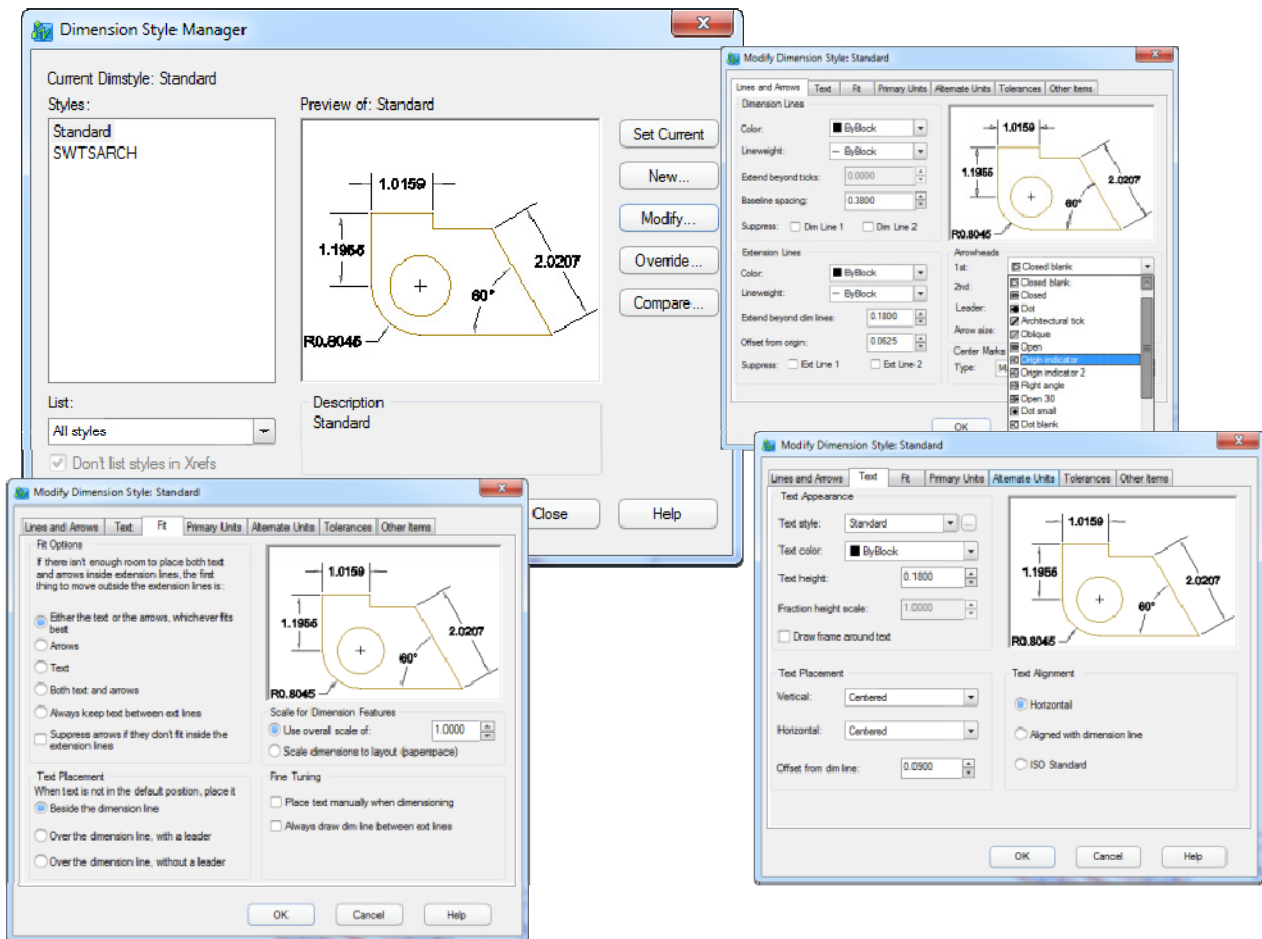

9. Block

9.1. Create and insert blocks

A block can be composed of objects drawn on several layers with various properties.

Create a block

We can create block by command Block and WBlock. Command Block is used to create block within a drawing. Define a block via the dialog box:

1. Name the block
2. Specifies an insertion base point for the block.
3. Specifies the objects to include in the new block

Command WBlock is used to create drawing files for

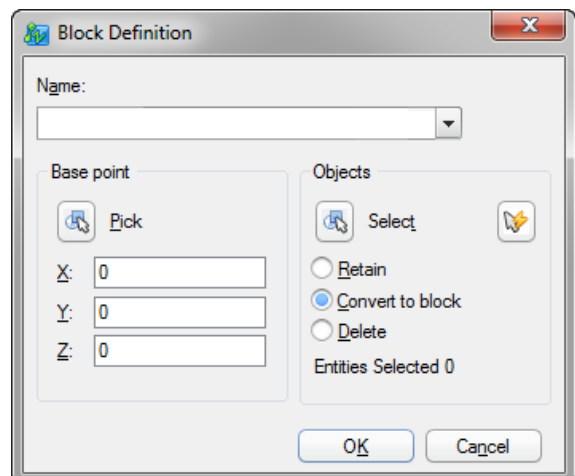

use as blocks.

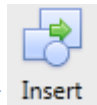
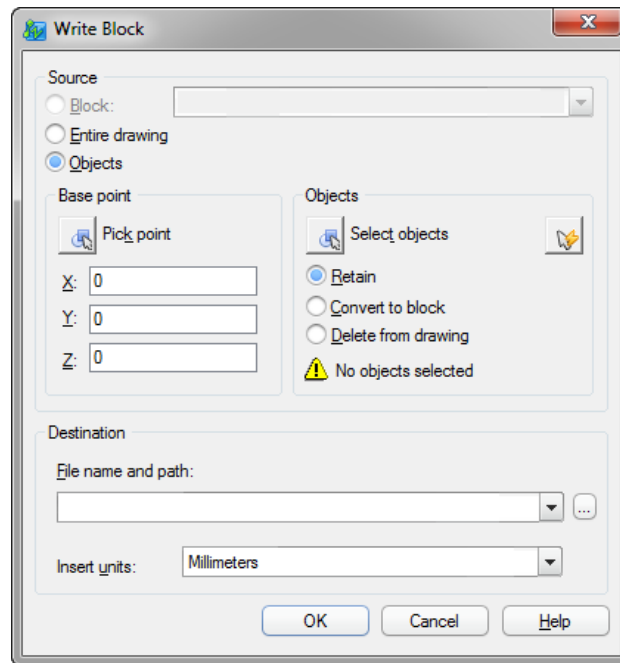

Insert a block

Insert

After a block is created, it can be used in the drawing by command Insert.

Input the information in Insert dialog box:

- 1) Select the block from the list.
- 2) Specify the insertion point, scale, and rotation
- 3) Click OK.

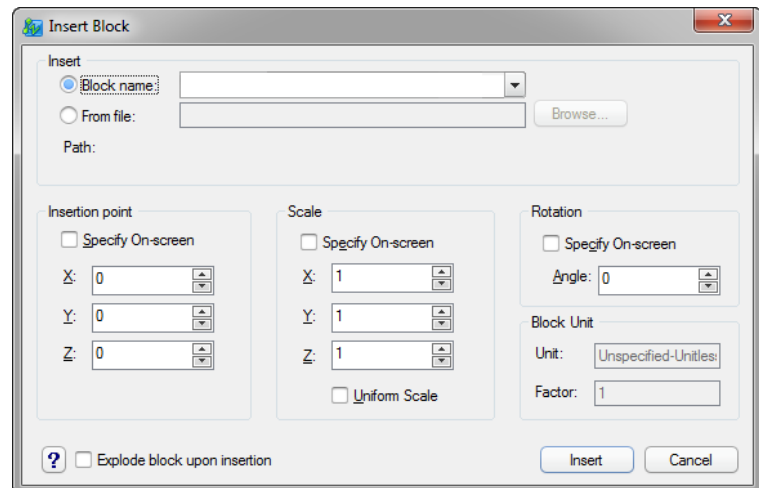

Tips & Tricks

In the 'Insert Block' dialog box, you can insert a drawing as block by the option 'From file'. Except commands Block and WBlock, you can also insert block from design center or tool palettes, by dragging the block into the drawing.

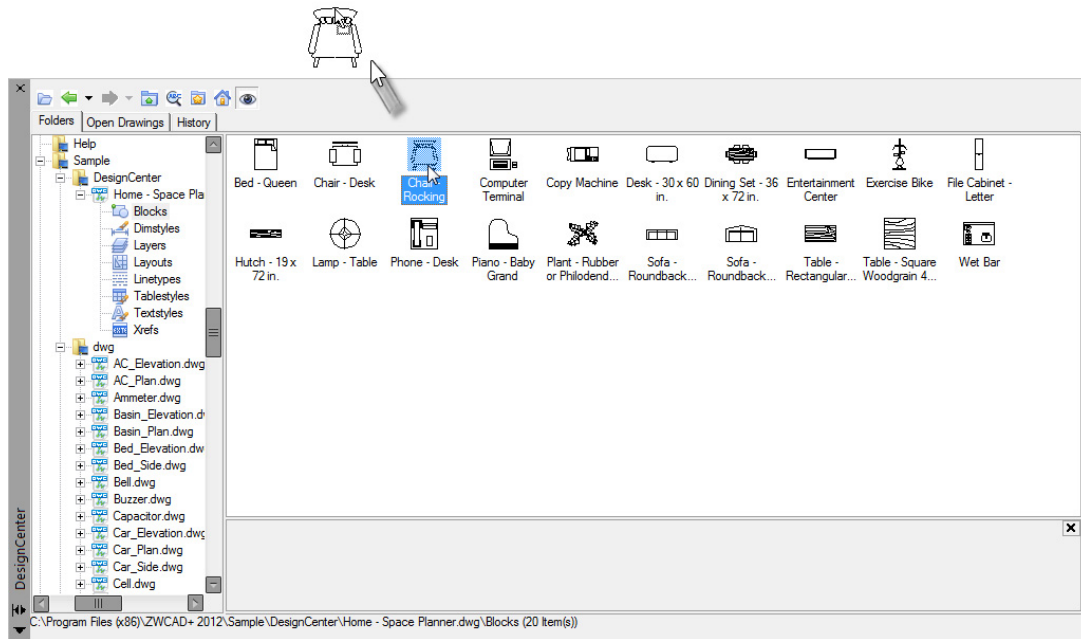

9.2. Block with attributes

An attribute is a label or tag that attaches data to a block. Examples of data that might be contained in an attribute are part numbers, prices, comments, and owners' names.

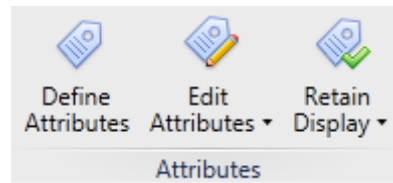

To create an attribute block, you need to create the attribute by command `attdef`, then use command `Block/WBlock` to select the geometric object together with the attribute object.

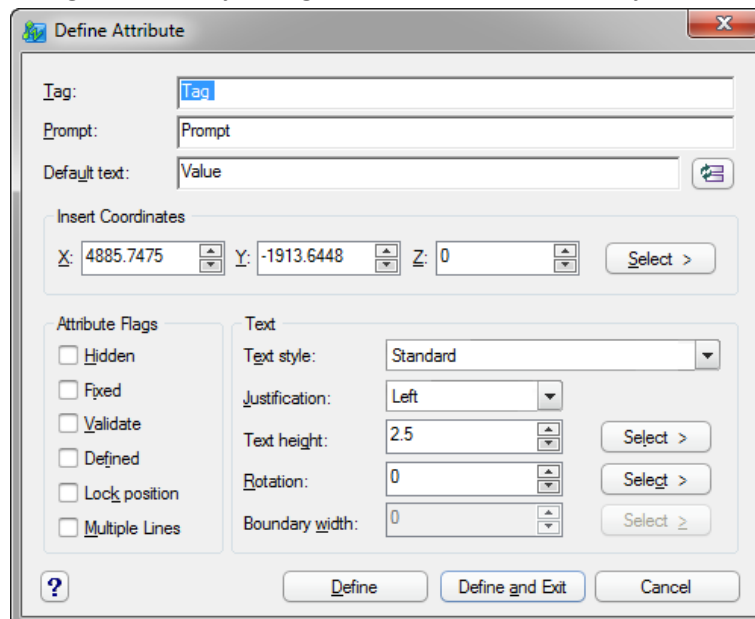

When you insert a block that has a variable attribute, you are prompted to enter data to be stored with the block.

You can change the attribute value of the block by double click the attribute block, or command attedit.

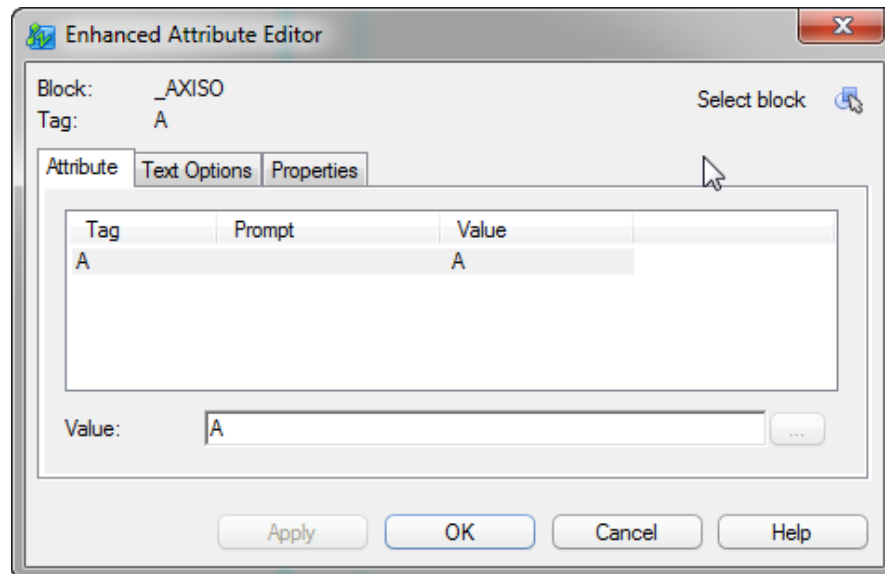

10. Share Data: xrefs, dwf, images

10.1. About External Reference

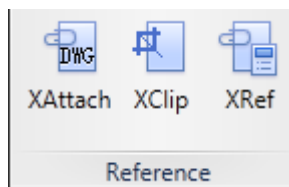

You can attach an entire drawing to the current drawing as a referenced drawing. With xrefs, changes made in the

referenced drawing are reflected in the current drawing.

Attached xrefs are linked to, but not actually inserted in, another drawing. Therefore, with xrefs you can build drawings without significantly increasing the drawing file size.

10.2. Attach External Reference

There are two ways to insert external reference into the drawing. You can use command XAttach, or use External Reference Manager.

When using command XAttach to insert xrefs, you can specify the insertion scale, position and rotation angle in the dialog box.

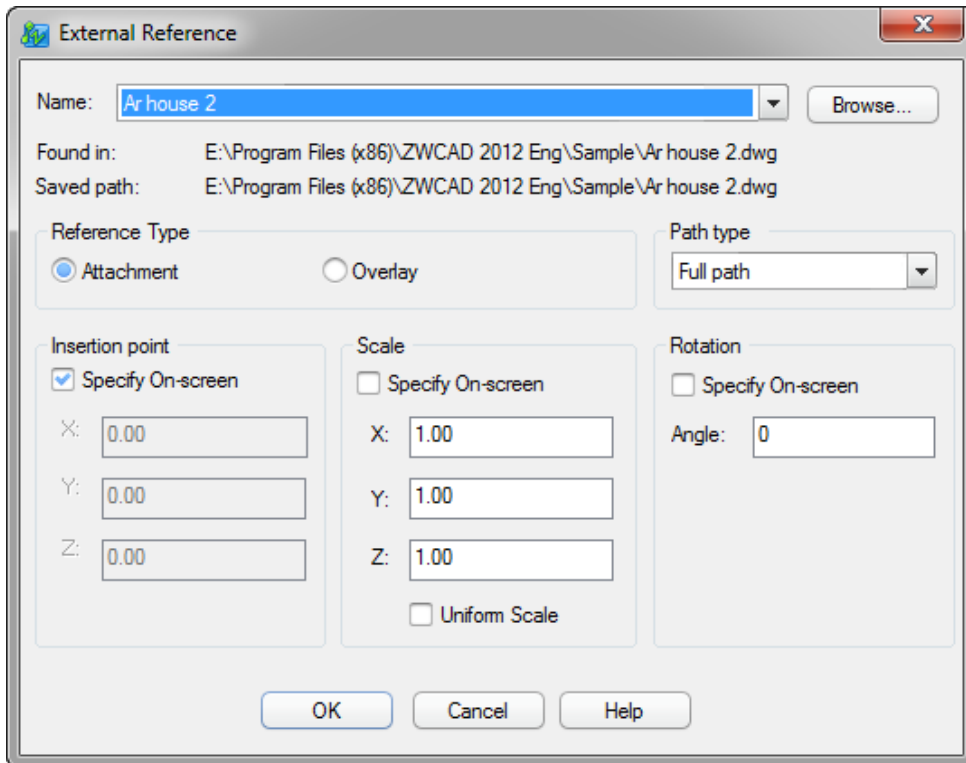

To attach External Reference by External Reference Manager, input command XRef or click XRef button from the ribbon menu. Click Attach button to browse a drawing as external reference, specify the scale, position and rotation angle in the dialog box.

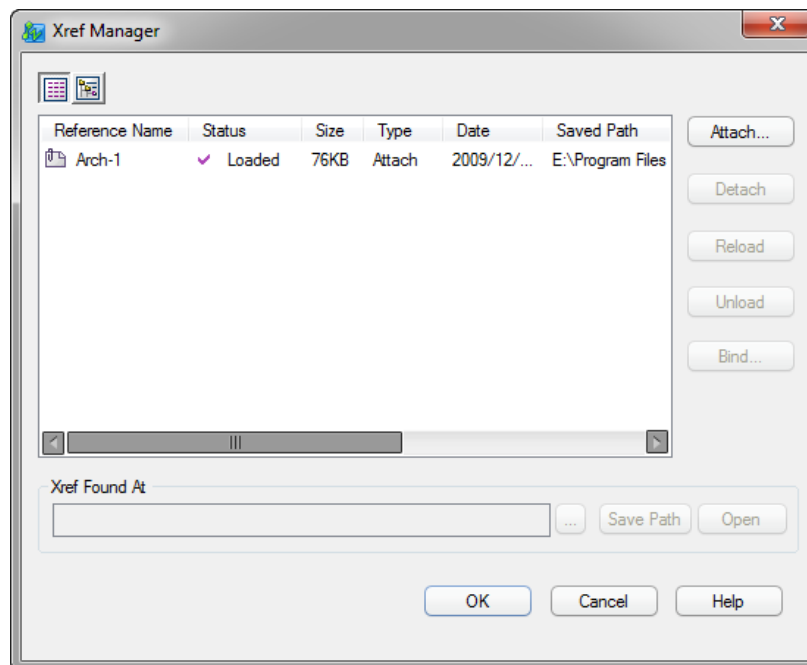

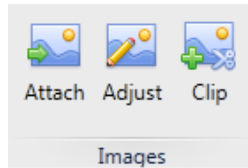

10.3. Attach image

You can attach a raster image file to a drawing file using ImageAttach or Image Manager. ZWCAD+ support image formats includes bmp, ecw, gif, jpg/jpeg, pcx, png, tga, tif/tiff.

When you attach an image file, you link that referenced file to the current drawing. Any changes to the referenced file are displayed in the current drawing when it is opened or reloaded

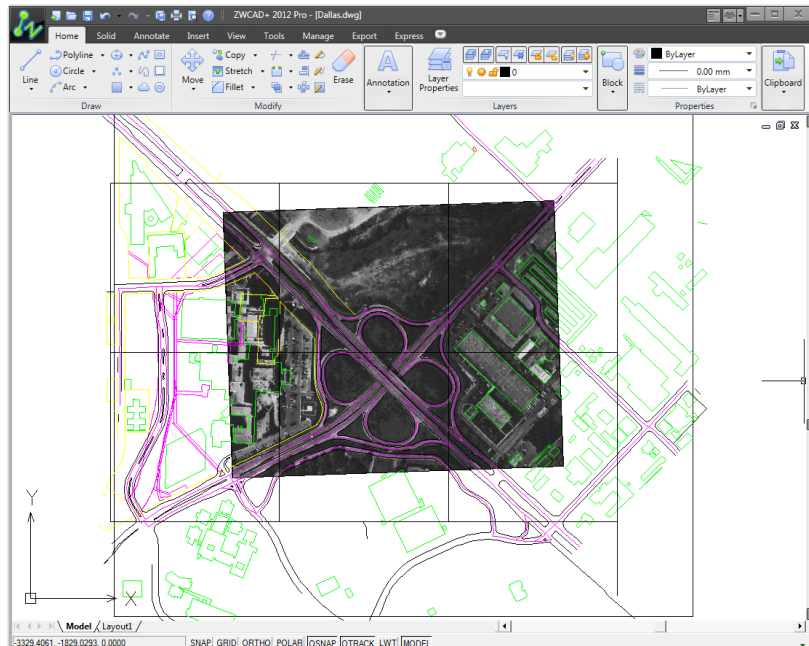

When using command ImageAttach to attach images to the drawing, you can specify the insertion scale, position and rotation angle in the dialog box.

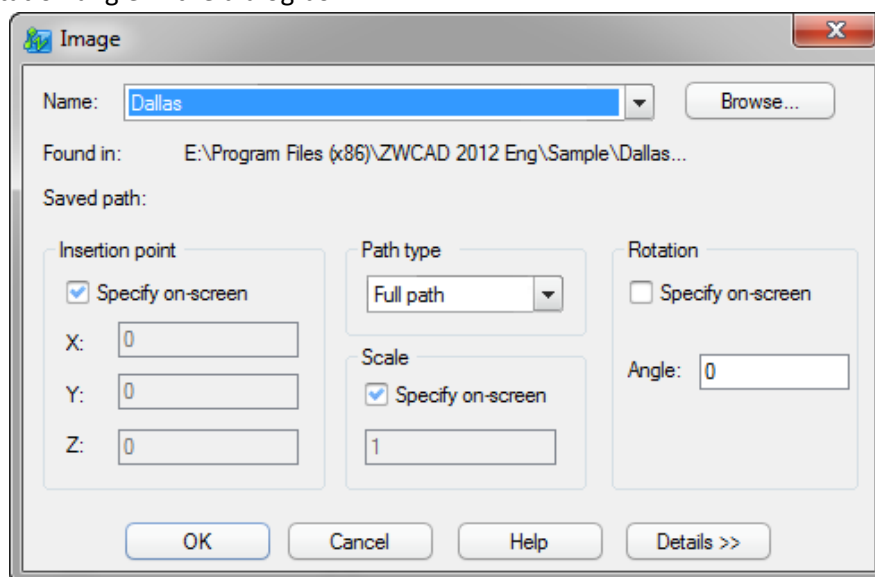

You can also attach raster image by Image Manager, inputting command Image to open the Image Manager Dialog box, click Attach button to browse raster image, specify the insertion scale, position and rotation angle in the dialog box. With Image Manager dialog box, you can also detach, reload, unload or save the path of the raster image.

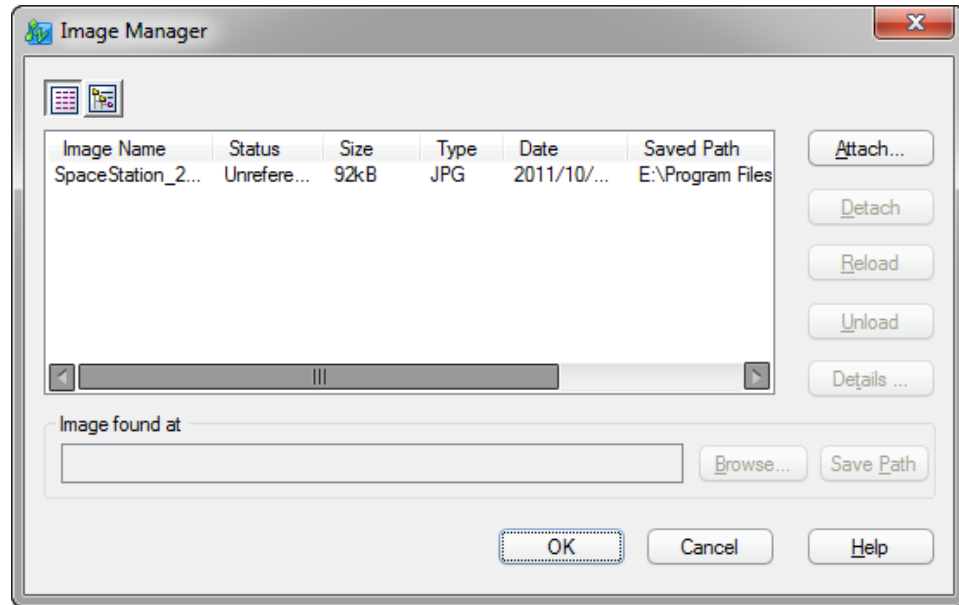

Tips & Tricks

You can use command ImageClip to crops the display of a selected image to a specified boundary, use command ImageAdjust to controls the image display of the brightness, contrast, and fade values of images.

11. Plotting and publishing drawings

Plotting is to have a paper printout of the electronic drawings. You can specify what and how to express your drawing content in a dedicated way by the settings before plotting. Publishing is to publish an electronic sheet set once in a time for later viewing/printing/exchanging/uploading. You can modify the sheet set by the publish manager.

11.1. Plotting drawings using plot manager

The plot manager will guide you step by step to do your plot job by the following instructions. Open the plot manager from the ribbon tab Export|Plot or the classic menu File|Plot...

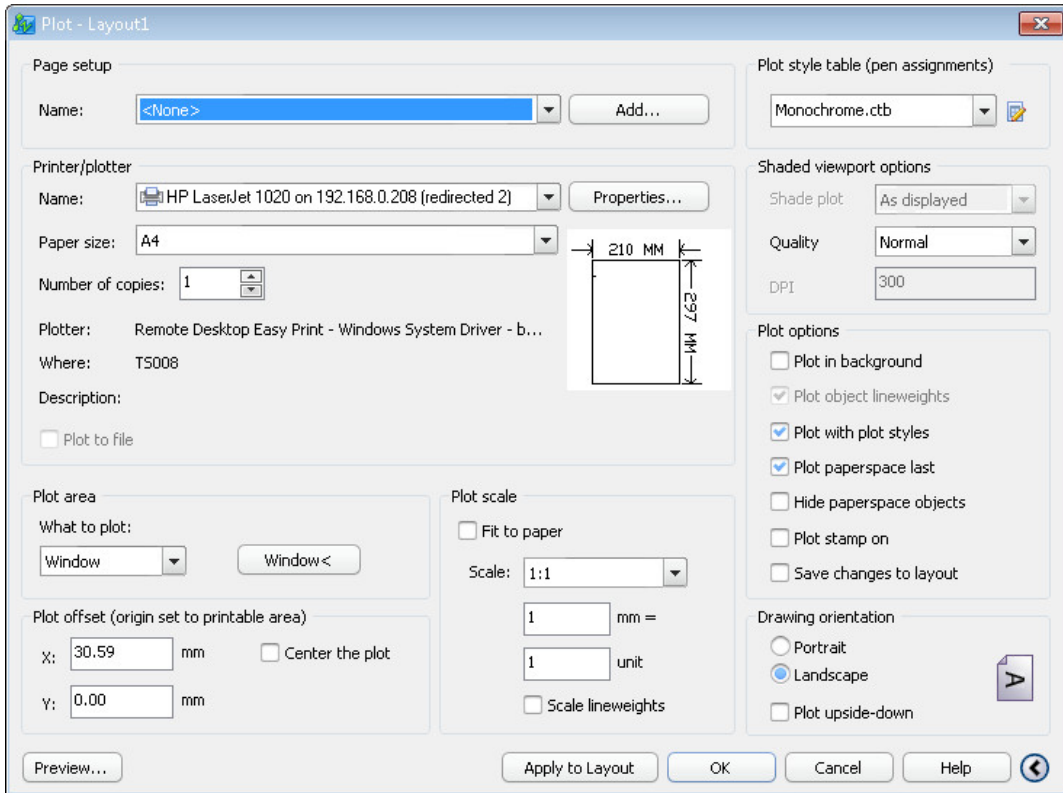

11.1.1. Page setup

A page setup is a series of settings stored as one named item shown on the top of the plot manager dialog, which saves all settings on the plot manager for future reference. You can use a named page setup whenever you want after saving. Click Add... to save the settings currently shown on the page and select one of them from the drop-down list. The page setup named None is generally used by default.

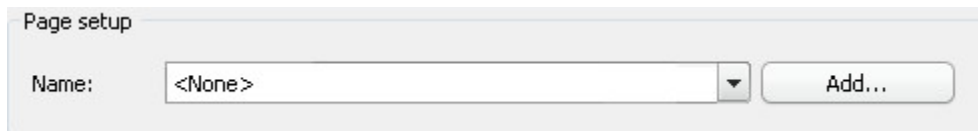

11.1.2. Printer/plotter settings

Specify the options below

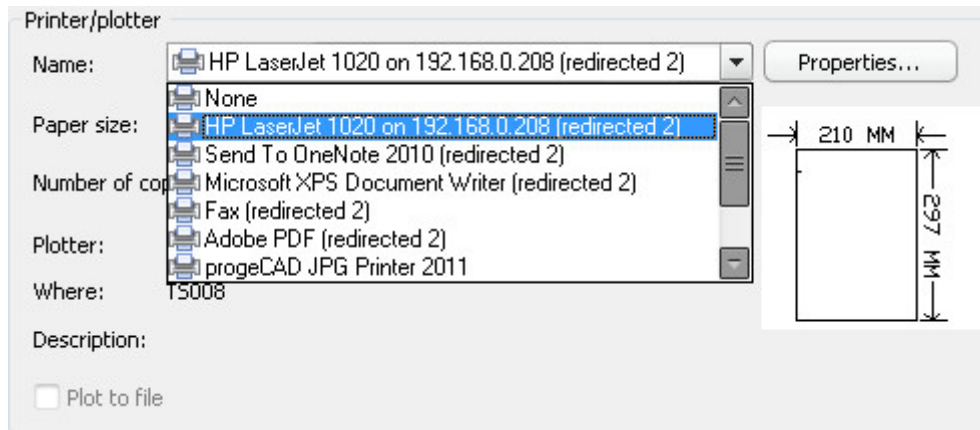

- 1) Select one device from the drop-down list to output your drawing.
- 2) Select one paper size you want the drawing to be put onto.
- 3) Specify the numbers of copies you want for this time.

11.1.3. Plot area and scale options

Select one option to specify the plot area from the drop-down list.

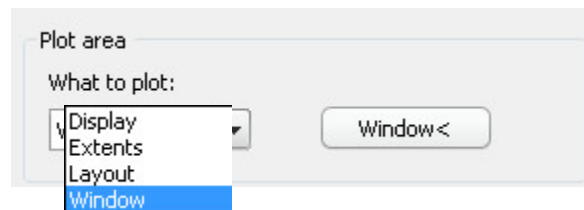

- **Display:** Prints all objects in the current view of your ZWCAD+ drawing area
- **Extents:** Prints all objects in the drawing.
- **Layout:** Prints all objects within the paper area specified in the paper space. This option is only available from a Layout tab.
- **Window:** Prints objects you will define in a rectangular window. Select the Window option, and then respond to define the area.

11.1.4. Other options

- **Drawing orientation:**

Determines whether the position of the printed drawing is landscape or portrait. You can also choose to plot upside-down.

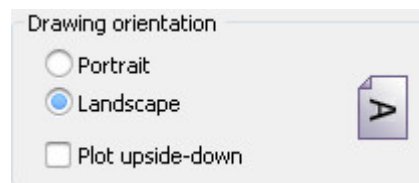

- **Plot scale:**

Controls how much the entire drawing will be scaled on the printout. Usually check Fit to paper for convenience to have all ready-to-print objects included in the printable area.

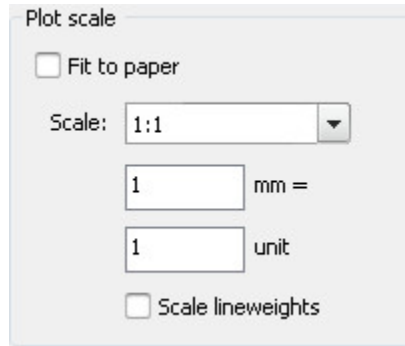

- **Plot offset:**

Changes the position of the printable area relative to the lower-left corner of the default area of printer. Usually check Center the plot for convenience.

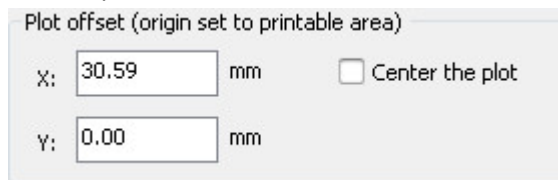

- **Plot style table:**

Specifies how the objects in the drawing will appear. Usually select None if you don't need it.

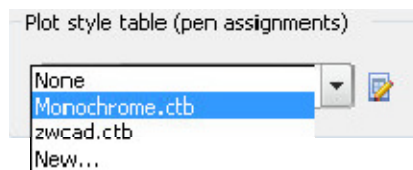

- **Shaded viewport options:**

Chooses whether to plot 3D objects in wireframe, hidden mode, a visual style, or rendered.

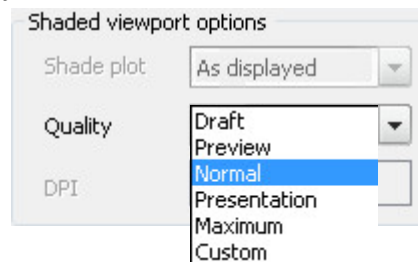

- **Other options to customize your printout at ease.**

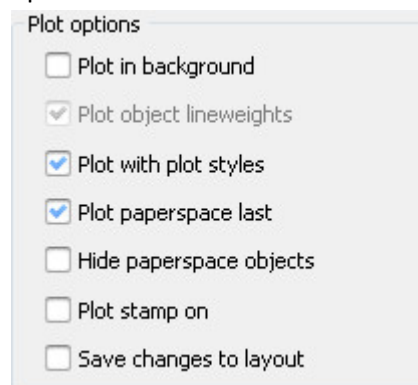

11.1.5. Layouts in paper space

A layout in paper space is a virtualized sheet of paper with all settings specified already. It represents a drawing sheet in appearance and can be modified/published/added once initialized.

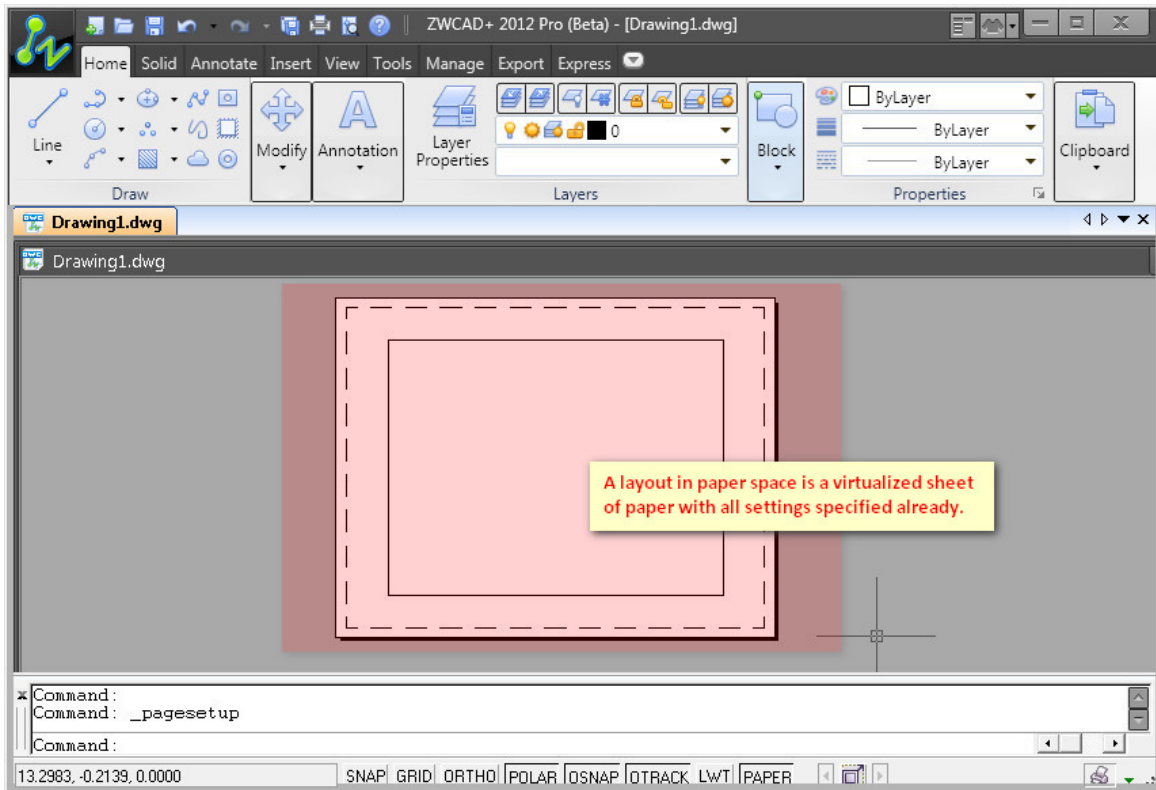

To initialize a paper layout, just click the layout tab and choose Page setup manager.

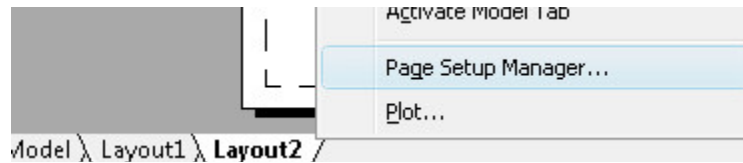

Click Modify to start it over as described in the chapter Plotting drawings using plot manager.

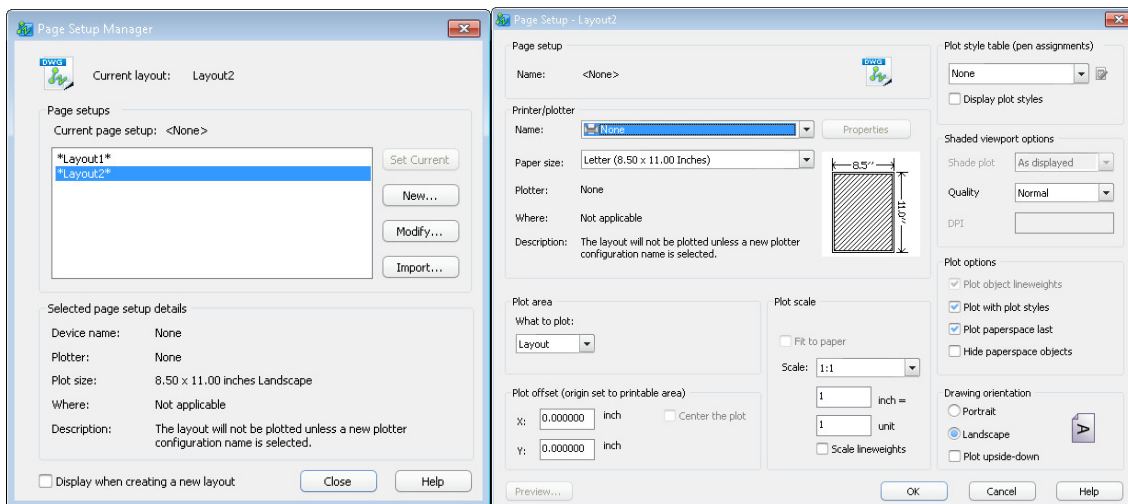

11.2. Publishing a sheet set of drawings using publish manager



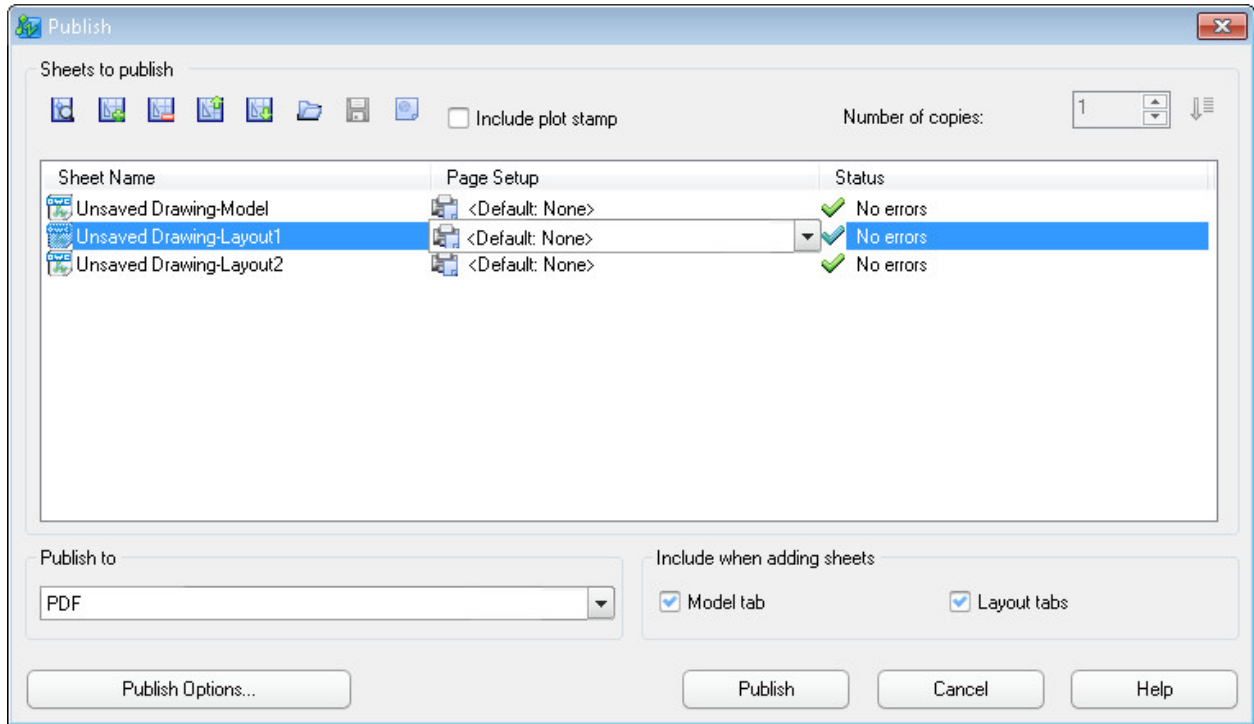

Publishing is to create a drawing sheet set by the publish manager. No matter in paper or electrically, the publish manager assemble a collection of drawings to be customized for your purpose.

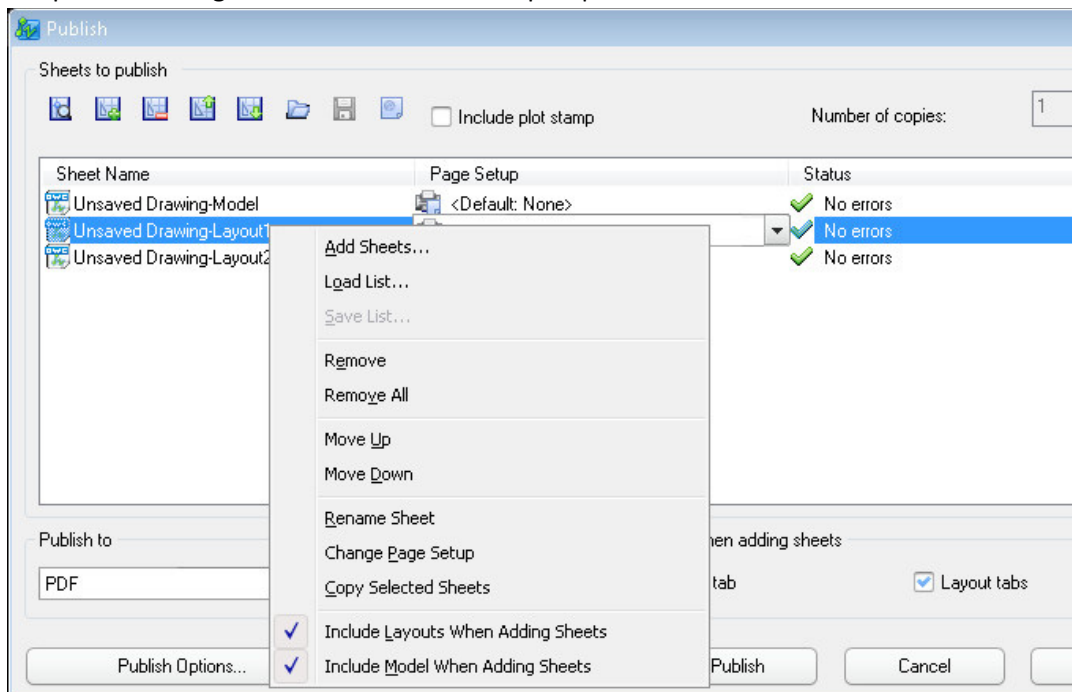

11.2.1. Publishing drawings using publish manager

The publish manager will help you collect drawing sheets and configure to get ready for publishing. Open the publish manager from the ribbon tab Export | Publish



- ✓ Add drawings and sheets from the button Add Sheets;
- ✓ You can modify the list of sheets in the dialog box by adding/removing/reordering/rename from the buttons on the page or the right-click menu;
- ✓ When your list of drawing sheets is assembled and configured, click the Publish button to start publishing .

11.2.2. Configuring publish options

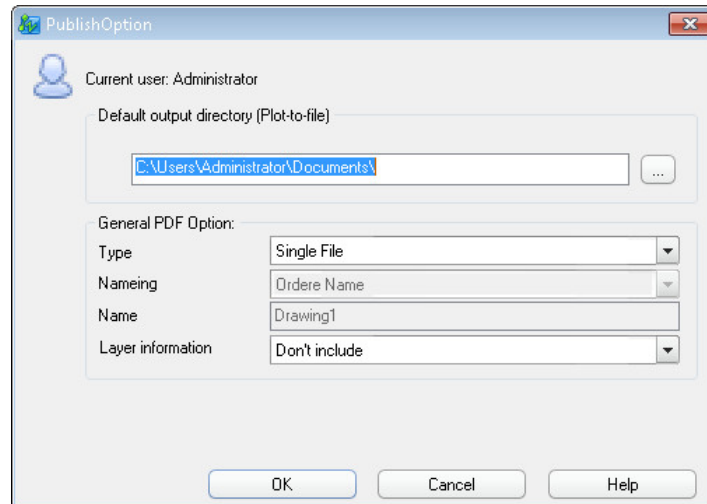

- **Default output directory:** Specifies where to put the generated PDF file by default.
- **General PDF option:** Specifies whether a single-sheet PDF or a single multi-sheet PDF is generated for the listed drawings and whether to have layer information included or not.

12. Work with 3D Models



12.1. Create 3D Models

ZWCAD+ supports several kinds of 3D entities, including solids, surfaces and meshes. In Ribbon environment, you can work with all 3D functions in Solid tab.

12.1.1. Solid Primitives

There are 6 kinds of solid primitives that can be created directly. In Solid tab > Primitive panel, they are Box, Cylinder, Sphere, Wedge, Cone and Torus.

To create a Box, it's better to change the view to Isometric View first. You can choose one of them in Ribbon: View tab > Views panel, such as SW Isometric.

- **BOX**

Click the Box button or enter BOX command to start creating a box. First, you need to specify the corner of the bottom face of the box, and then specify the other corner of the bottom face. Finally, specify a length as the height of the box.

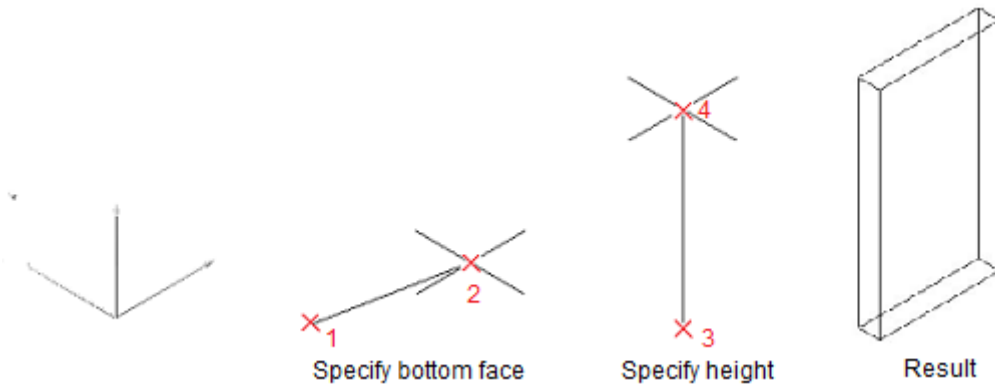

- **Torus**

Click the Torus button or enter TORUS command to start creating a torus. First, you need to specify the radius of the whole torus, and then specify the radius of tube (thickness of torus).

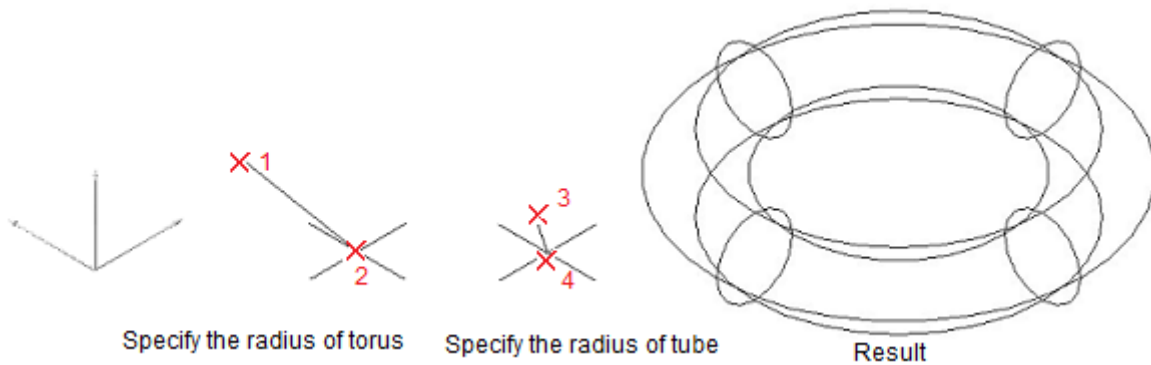

Creating Cylinders, Spheres, Cones, Wedges are all similar with above. You can follow the command prompt to create them yourself.

12.1.2. Create Solid from 2D profiles

Besides creating solid by preset primitives, you can also use other ways to create specifically-shaped solids.

- **Extrude**

You can extrude a closed polyline or region to a 3D model by using EXTRUDE command (On Ribbon: Solid Tab > Solid Panel). First, you need to draw a closed polyline or convert a closed area to region. Then, use EXTRUDE command, and specify the length of extrusion and taper angle.

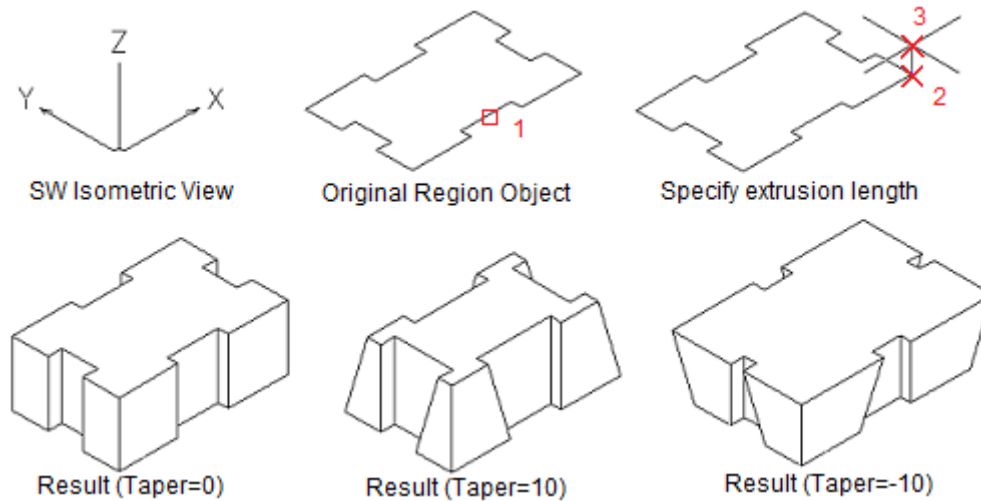

- **Revolve**

REVOLVE command (on Ribbon: Solid Tab > Solid Panel) is used for creating 3D solid or surface by sweeping an object around an axis. First, you need to draw a profile that you want to revolve. Then, use REVOLVE command, and specify the axis and revolve angle. Open profiles create surfaces and closed profiles create solids.

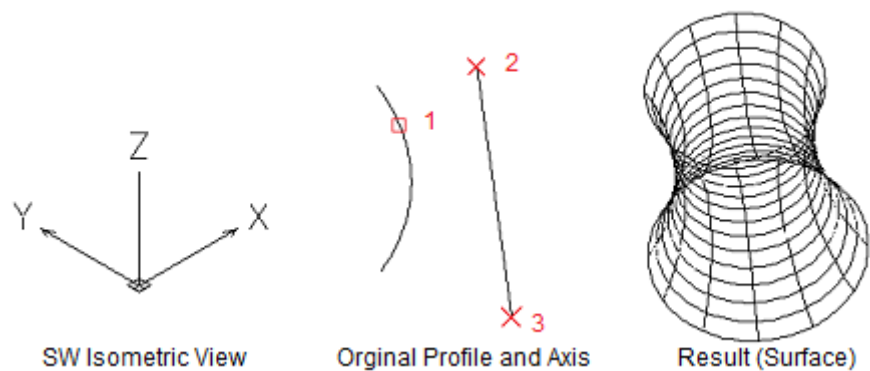

12.1.3. Create Mesh Primitives

Mesh object provides enhanced capabilities for modeling object shapes in a more detailed way. It provides the ability to edit the grips directly.

Creating mesh primitives is similar like creating solid primitives. You can find them on Ribbon: Solid Tab > Mesh Panel.

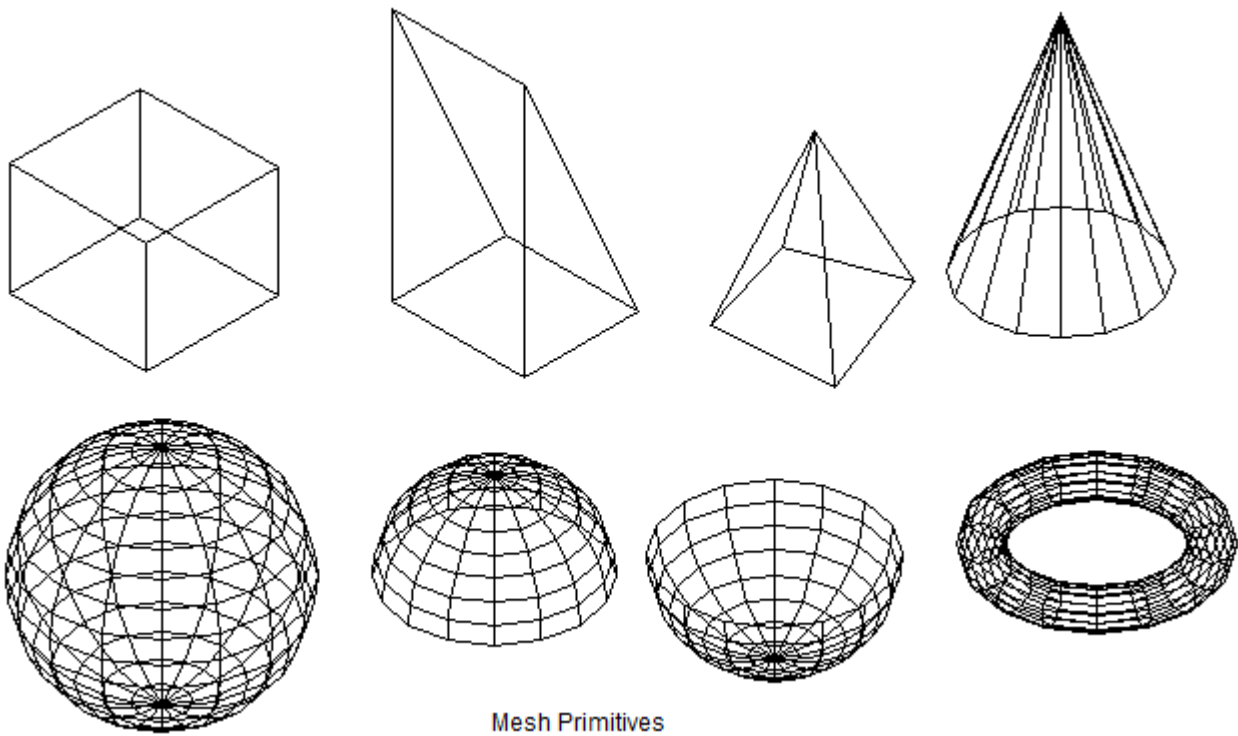

12.2. Modify 3D Models

There are many 3D editing tools to make your solid models become what you want. Including Boolean Calculation, Solid Editing and 3D Operation (All on Ribbon: Solid Tab).

12.2.1. Boolean

Boolean operations are used for combining multiple solids or regions. There are three kinds of Boolean operation which are Union, Subtract and Intersect.

Union operation combines selected 3D solids or 2D regions by addition. Just use UNION command and select all the objects you want to union and press Enter.

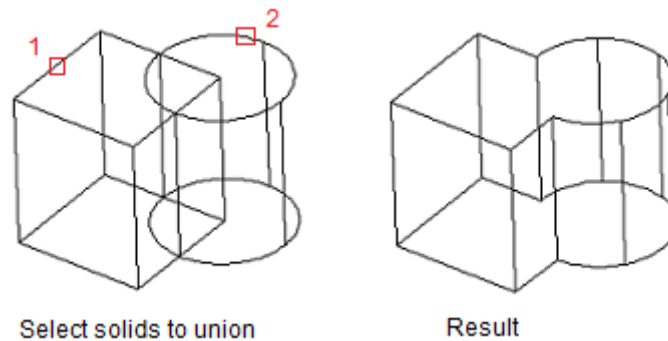

Subtract operation combines selected 3D solids or 2D regions by subtraction. Use SUBTRACT command, select the solids that you want to keep, press Enter, then select the objects that you want to subtract.

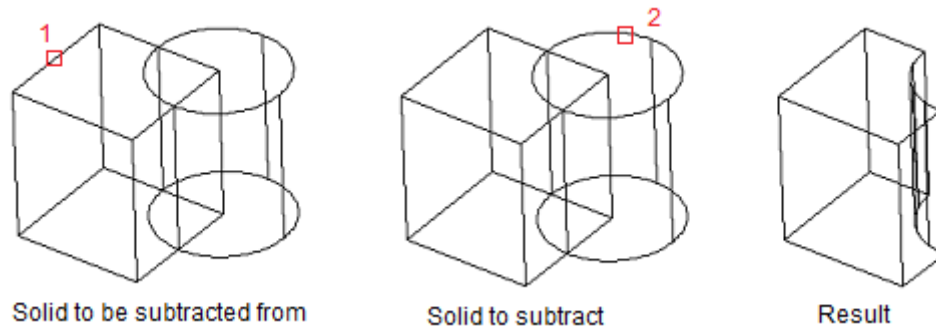

Intersect operation creates a 3D solid or 2D region from overlapping solids or regions. Just use INTERSECT command and select all the objects you want to intersect and press Enter.

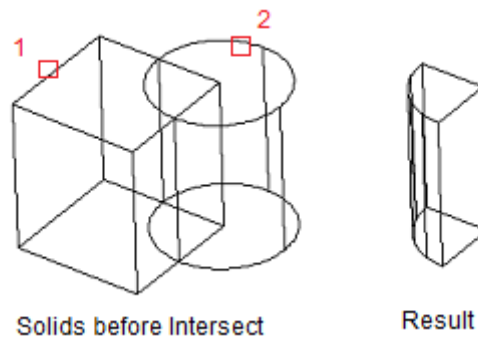

12.2.2. Solid Editing

SOLIDEDIT command includes the methods to edit bodies (solids), faces and edges, which are all placed on Ribbon: Solid Tab > Solid Editing Panel.

With this command, you can imprint, separate, shell, clean, and check the validity of the entire 3D solid object (body). You can extrude, move, rotate, offset, taper, copy, delete, and assign colors and materials to faces. You can also copy and assign colors to edges.

You cannot use SOLIDEDIT with mesh objects.

Here shows some example to use SOLIDEDIT.

- **Body Shell**

Shelling creates a hollow, thin wall with a specified thickness. You can specify a constant wall thickness for all the faces. You can also exclude faces from the shell by selecting them. A 3D solid can have only one shell. New faces are created by offsetting existing ones outside their original positions.

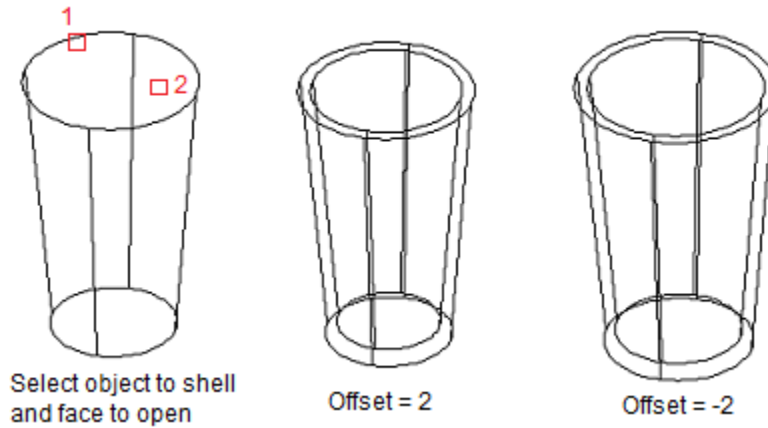

- **Face Extrude**

Extends a 3D solid face in the X, Y, or Z direction. You can change the shape of the object by moving its faces.

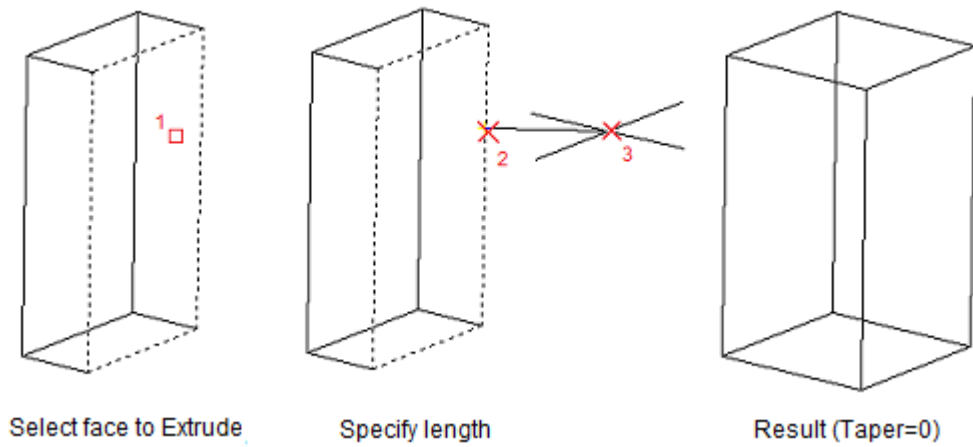

- **Edge Copy:**

Copies selected edges on a 3D solid as 2D arcs, circles, ellipses, lines, or splines.

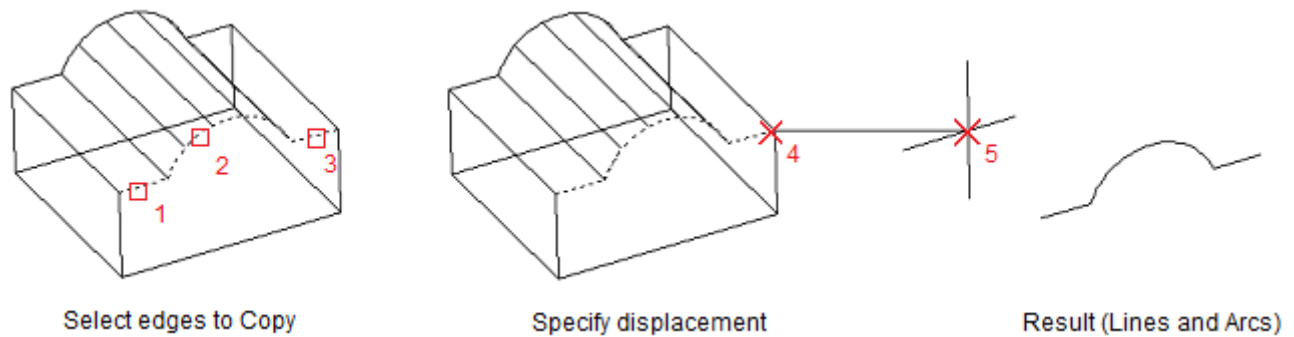

12.3. View 3D Models

You can view your 3D models in different way in order to suit different situation.

12.3.1. 3D Orbit

3D orbit is to rotate the view in 3D space, so that you can view the model from different angle and face, just like you watch an object around in the real world. It's very helpful for you to see the whole picture of your 3D models.

After starting 3DORBIT command, you can move the cursor inside the orbit loop, hold your left mouse button and move around to orbit the model freely.

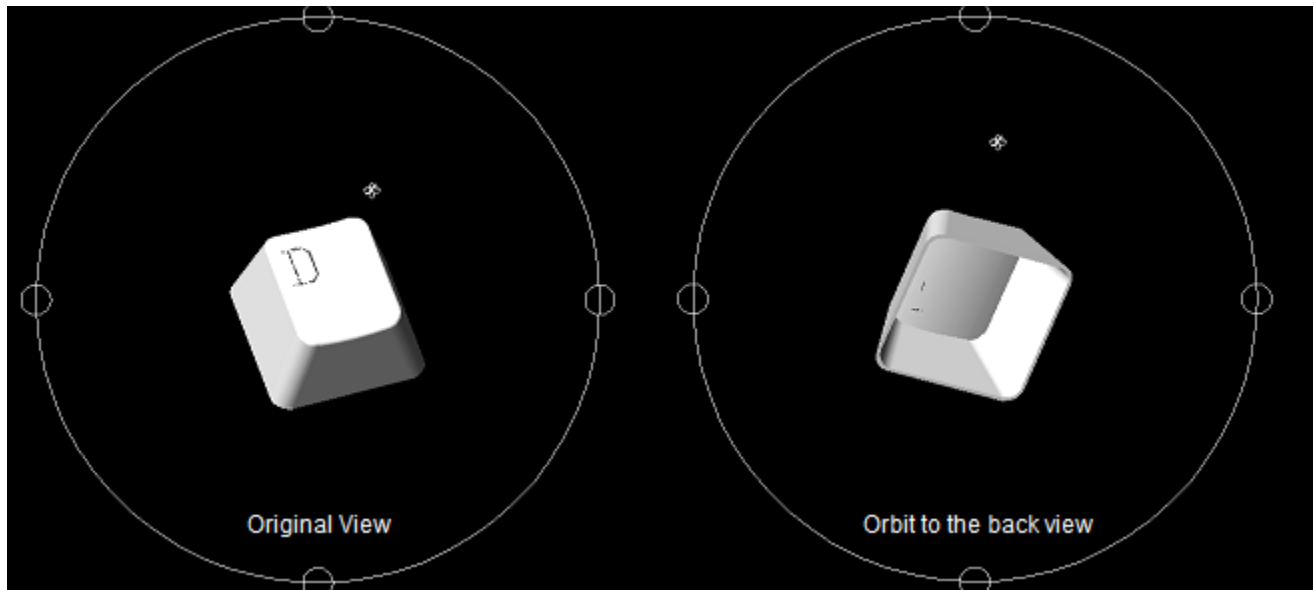

You can also move your cursor into the small circle positioned at each quarter of the orbit loop, in which

the cursor will change its icon to: . It means that when you rotate the view here, you can rotate with a certain virtual axis that is tangent to the big orbit loop.

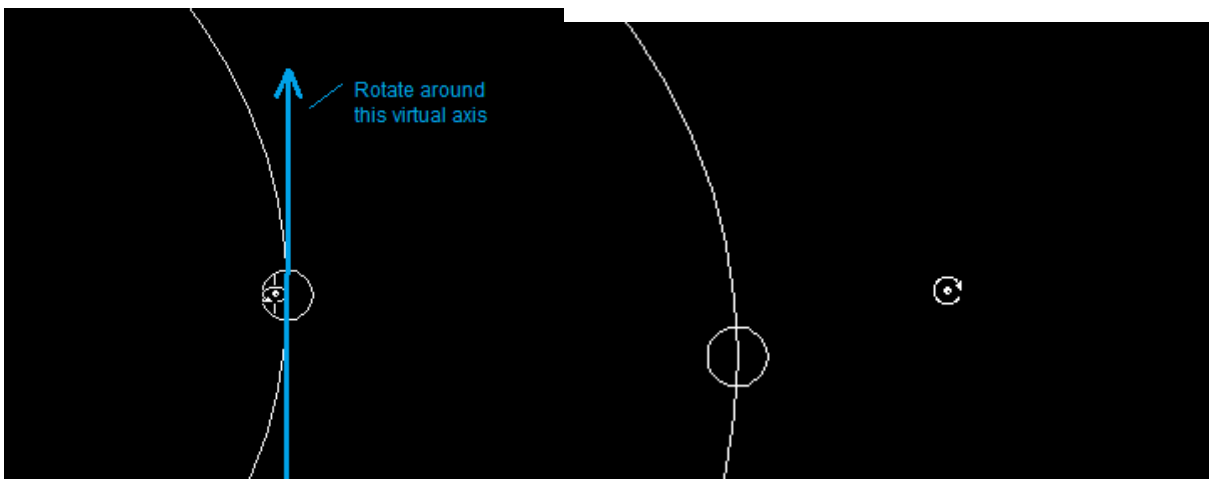

If you move your cursor outside the big orbit loop, you can rotate the view in the plan of screen, which means the rotate axis is perpendicular to your screen.

You can also right-click in the drawing area to show the 3D orbit contextual menu, in which many extra functions are provided. Such as you can choose More > Continuous Orbit, and then drag your mouse for a short distance and release, then you will find the view starts to orbit itself continuously and automatically.

Tips & Tricks

The faster you drag, the faster the Continuous Orbit will be.

Another useful function in this contextual menu is switching between Parallel and Perspective View. You can choose Projection > Perspective to switch to the Perspective view, which is more like how you see things in the real world.

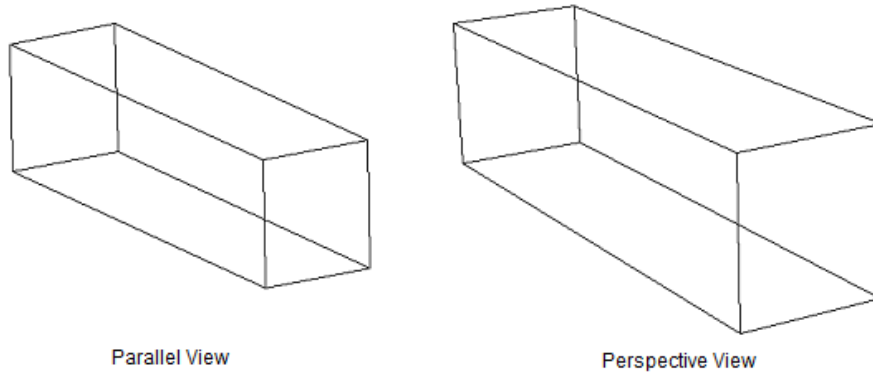

12.3.2. Visual Styles

A visual style is a collection of settings that control the display of edges, shading, and shadows of 3D solids and surfaces in the current viewport.

In ZWCAD+, you can switch among different visual styles easily with Ribbon. In View Tab > Visual Styles Panel, there is a drop-down list box with all visual styles listed with previews.

There are 7 visual styles provided, which are:

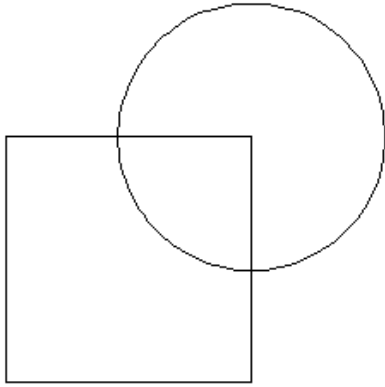

2D Wireframe

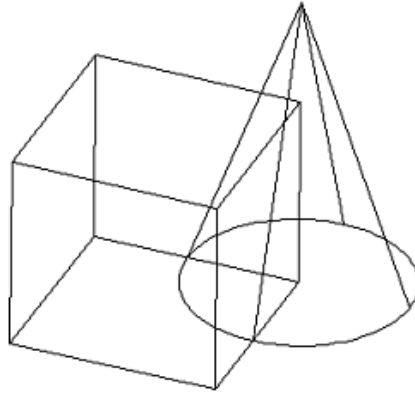

3D Wireframe

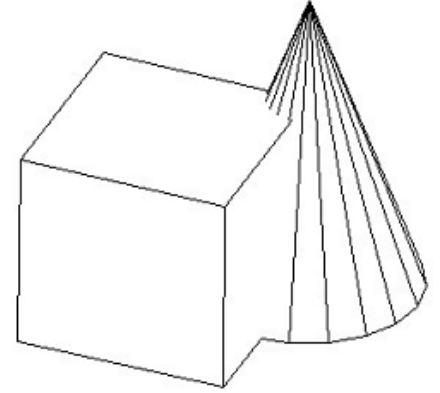

Hidden

- **2D Wireframe.** Normally used for 2D drafting and editing. Objects are displayed with only edges without shading.
- **3D Wireframe.** Similar to 2D Wireframe but for 3D modeling. Operate with 3D models in this style is smooth and fast, so it's very suitable for most 3D modeling work.
- **Hidden.** Objects displayed with only visible edges, and without shading, either. Edges that hidden behind or inside objects will not be displayed, which is very suitable to see the outlines of models. But if your 3D models are too complicated, using Hidden style might affect your operation speed.

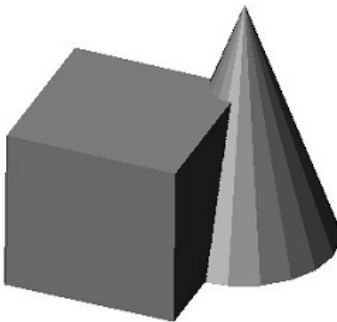

Flat

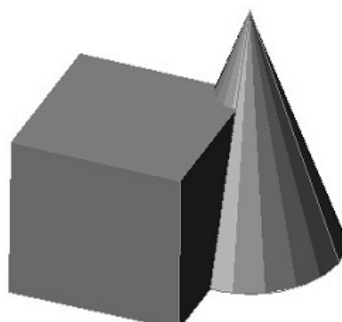

Flat with Edge

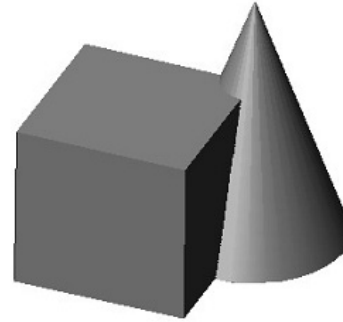

Gouraud

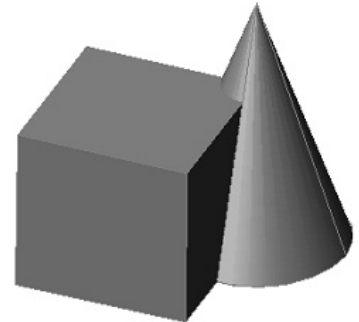

Gouraud with Edge

- **Flat.** Objects displayed without edges, but with simple shading. Surfaces displayed in this style are not smooth but all flat
- **Flat with edges.** Similar to Flat style, but with edges.
- **Gouraud.** Object displayed without edges, but with higher quality shading. Surfaces displayed in this style are smooth. It's very suitable for final viewing of your models.
- **Gouraud with edges.** Similar to Gouraud style, but with edges.